

# A SURVEY OF CLONES CLOSED UNDER CONJUGATION

ÁGNES SZENDREI

ABSTRACT. There is a Galois connection between the lattice of clones on a set  $A$  and the group of permutations on  $A$  that is determined by the relation that a permutation conjugates a clone onto itself. The Galois-closed sets on the clone side are the lattices  $L_G$  of all clones that are closed under conjugation by all members of some permutation group  $G$ . In this paper we discuss the coarse structure of the lattice  $L_G$  when  $A$  is finite and  $G$  is a 2-homogeneous permutation group, describe  $L_G$  completely for the case when  $G$  is the group of all permutations, and discuss for which groups  $G$  the lattice  $L_G$  is finite.

## 1. INTRODUCTION

Many important symmetries of algebras are not automorphisms. For example, inversion  $\gamma: G \rightarrow G$ ,  $g \mapsto g^{-1}$  is an antiautomorphism of a group, and this is a type of symmetry that is not an automorphism (unless  $G$  is abelian). Transpose  $\gamma: M_n(\mathbb{R}) \rightarrow M_n(\mathbb{R})$ ,  $A \mapsto A^T$  is an antiautomorphism of a matrix ring, which is a symmetry that is not an automorphism (unless  $n = 1$ ). Complementation  $\gamma: \mathbf{B} \rightarrow \mathbf{B}$ ,  $b \mapsto \bar{b}$  in a Boolean algebra is a symmetry that is not an automorphism. If  $K$  is a field and  $\sigma$  is an automorphism of  $K$ , then the coordinatewise action of  $\sigma$  defines a symmetry  $\gamma: K^n \rightarrow K^n$ ,  $\langle k_1, \dots, k_n \rangle \mapsto \langle \sigma(k_1), \dots, \sigma(k_n) \rangle$  of the  $n$ -dimensional  $K$ -vector space  $K^n$  that is not an automorphism (unless  $\sigma = \text{id}$ ).

The kind of symmetry exhibited by these examples is the focus of this paper. For the general concept, let  $A$  be a set and  $\gamma$  be a permutation of  $A$ . If  $f: A^n \rightarrow A$  is an operation on  $A$ , we define the conjugate of  $f$  by  $\gamma$  to be

$$\gamma f(x_1, \dots, x_n) = \gamma f(\gamma^{-1}(x_1), \dots, \gamma^{-1}(x_n)).$$

The conjugate of a set  $F$  of operations by  $\gamma$  is  $\gamma F = \{\gamma f : f \in F\}$ , and the conjugate of an algebra  $\mathbf{A} = \langle A; f_1, f_2, \dots \rangle$  by  $\gamma$  is the algebra  $\gamma \mathbf{A} = \langle A; \gamma f_1, \gamma f_2, \dots \rangle$ . It is easy to see that  $\gamma$  is an automorphism of  $\mathbf{A}$  if and only if  $\gamma f_i = f_i$  for all fundamental operations  $f_i$  of  $\mathbf{A}$ . The common feature of the symmetries mentioned in the preceding paragraph is that they are permutations  $\gamma$  of the underlying set of an algebra  $\mathbf{A} = \langle A; f_1, f_2, \dots \rangle$  such that  $\mathbf{A}$  and  $\gamma \mathbf{A}$  have the same term operations. Such

---

1991 *Mathematics Subject Classification*. Primary 08A05, Secondary 08A40, 08A35, 03B50.

*Key words and phrases*. Clone, conjugation, weak automorphism.

This material is based upon work supported by the Hungarian National Foundation for Scientific Research (OTKA) grants no. T 026243, T 034175, T 37877.

a permutation  $\gamma$  is called a weak automorphism of  $\mathbf{A}$ . In other words,  $\gamma$  is a weak automorphism of  $\mathbf{A}$  if and only if the clone  $\mathfrak{C}$  of term operations of  $\mathbf{A}$  satisfies the equality  $\gamma\mathfrak{C} = \mathfrak{C}$ .

For any fixed permutation  $\gamma$  on a set  $A$ , conjugation by  $\gamma$  yields an automorphism  $\mathfrak{C} \mapsto \gamma\mathfrak{C}$  of the lattice of all clones on  $A$ . The condition  $\gamma\mathfrak{C} = \mathfrak{C}$  defines a Galois connection between clones on  $A$  and permutations on  $A$  as follows: we assign to every set of clones the collection of all permutations that fix every clone in the set, and to every set of permutations the collection of all clones that are fixed by every permutation in the set.<sup>1</sup> It is easy to see that the Galois-closed sets of clones are complete sublattices of the lattice of all clones, while the Galois-closed sets of permutations are subgroups of the symmetric group on  $A$ . For a permutation group  $G$ , the members of the Galois-closed set  $\{\mathfrak{C} : \gamma\mathfrak{C} = \mathfrak{C} \text{ for all } \gamma \in G\}$  of clones corresponding to  $G$  will be called  $G$ -closed clones. It is easy to see from the definitions that the family of  $G$ -closed clones includes all clones  $\mathfrak{C}$  that contain  $G$ , and also all clones  $\mathfrak{C}$  for which  $G$  is a group of automorphisms of the algebra  $\langle A; \mathfrak{C} \rangle$ .

Our aim in this paper is to give an overview of some results on the lattice of  $G$ -closed clones on a finite set when  $G$  is a large permutation group. In Section 3 we discuss Szabó's theorem [38] which can be used to determine the coarse structure of the lattice of  $G$ -closed clones, including all coatoms of the lattice, when  $G$  is a 2-homogeneous permutation group (a property slightly weaker than 2-transitivity). In Section 4 we present a complete description of all  $\mathcal{S}_A$ -closed clones where  $\mathcal{S}_A$  is the symmetric group on  $A$ . This description is a modified version of results obtained earlier by Hoa [15] and Marchenkov [28]. In Section 5 we briefly discuss a recent result [20] which lists all groups  $G$  such that the family of  $G$ -closed clones that contain all constants is finite. For each major theorem mentioned above we outline a proof which, in some cases, differs essentially from the proofs published earlier. Our goal is to emphasize the advantages of combining different methods: using operational and relational arguments simultaneously, which is facilitated by the Galois connection between operations and relations<sup>2</sup>, and applying localization and globalization from tame congruence theory in combination with these arguments.

Finiteness of the base set is crucial in these results and methods. For the case when the base set  $A$  is infinite, Goldstern and Shelah [10] obtained interesting results on a special class of  $\mathcal{S}_A$ -closed clones. They studied the lattice of all clones that contain the full transformation monoid on  $A$ , and found that the structure of this lattice depends heavily on partition (Ramsey) properties of the cardinality  $|A|$  of the base set. Specifically, if  $|A|$  is a weakly compact cardinal, then this lattice has exactly 2 coatoms, while if  $|A|$  is, say, the successor of an uncountable regular cardinal, then this lattice has  $2^{2^{|A|}}$  coatoms.

---

<sup>1</sup>This Galois connection is discussed in detail in the paper [8] in this volume.

<sup>2</sup>For more details about this Galois connection, see [34] in this volume.

## 2. PRELIMINARIES AND EXAMPLES

For any set  $A$ , a *clone* on  $A$  is a collection of finitary operations on  $A$  that contains the projection operations and is closed under composition. For any set  $F$  of operations on  $A$ ,  $[F]$  will denote the clone generated by  $F$ . In other words,  $[F]$  is the collection of all *term operations* of the algebra  $\mathbf{A} = \langle A; F \rangle$ , which is called *the clone of  $\mathbf{A}$* , and is also denoted by  $\text{Clo}(\mathbf{A})$ . If  $\mathbf{A} = \langle A; F \rangle$  is an algebra, then  $\mathbf{A}^c$  will denote the algebra that arises from  $\mathbf{A}$  by adding all constants as fundamental operations. The clone of  $\mathbf{A}^c$ , that is, the clone generated by  $F$  and all constants, is called *the clone of polynomial operations of  $\mathbf{A}$* , and is denoted by  $\text{Pol}(\mathbf{A})$ . For  $n \geq 1$ ,  $\text{Clo}_n(\mathbf{A})$  and  $\text{Pol}_n(\mathbf{A})$  will denote the set of  $n$ -ary term operations, and the set of  $n$ -ary polynomial operations of  $\mathbf{A}$ , respectively. A finite algebra  $\mathbf{A}$  is called *primal* if  $\text{Clo}(\mathbf{A})$  is the clone of all operations on  $A$ , and *functionally complete* if  $\mathbf{A}^c$  is primal. We will call  $\mathbf{A}$  a *projection algebra* if  $\text{Clo}(\mathbf{A})$  is the clone of projections. Two algebras are said to be *term equivalent* if they have the same clones, and they are said to be *polynomially equivalent* if they have the same clones of polynomial operations.

An operation  $f$  on  $A$  is *idempotent* if it satisfies the identity  $f(x, \dots, x) = x$ . An algebra  $\mathbf{A}$  is idempotent if all fundamental operations (and hence all term operations) of  $\mathbf{A}$  are idempotent. A clone  $\mathfrak{C}$  is idempotent if all operations in  $\mathfrak{C}$  are idempotent. A ternary operation  $f$  is a *Mal'tsev operation* if it satisfies the identities  $f(x, y, y) = f(y, y, x) = x$ ;  $f$  is a *minority operation* if it satisfies the identities  $f(x, y, y) = f(y, x, y) = f(y, y, x) = x$ ; and  $f$  is a *majority operation* if it satisfies the identities  $f(x, y, y) = f(y, x, y) = f(y, y, x) = y$ .

We will use the notation  $\mathcal{T}_A$ ,  $\mathcal{C}_A$ ,  $\mathcal{S}_A$ , and  $\mathcal{A}_A$  for the full transformation monoid, its subsemigroup of all constants, the symmetric group, and the alternating group on  $A$ , respectively. For  $|A| = 4$ ,  $\mathcal{V}_A$  will denote the Klein group on  $A$ .

Let  $\gamma \in \mathcal{S}_A$ . For an  $n$ -ary operation  $f$  on  $A$  the *conjugate* of  $f$  by  $\gamma$  is the operation

$${}^\gamma f(x_1, \dots, x_n) = \gamma f(\gamma^{-1}(x_1), \dots, \gamma^{-1}(x_n)).$$

The conjugate of a set  $F$  of operations by  $\gamma$  is defined as  ${}^\gamma F = \{{}^\gamma f : f \in F\}$ . It is straightforward to check that  ${}^\gamma \mathfrak{C}$  is a clone for every clone  $\mathfrak{C}$  and permutation  $\gamma$ , and the mapping  $\mathfrak{C} \mapsto {}^\gamma \mathfrak{C}$  defines an inner automorphism of the lattice of clones on  $A$  for every  $\gamma \in \mathcal{S}_A$ . If the clone of an algebra  $\mathbf{A}$  is fixed by this automorphism, that is, if  ${}^\gamma \text{Clo}(\mathbf{A}) = \text{Clo}(\mathbf{A})$  holds, then  $\gamma$  is called a *weak automorphism* of  $\mathbf{A}$  (see [8] or [9]). The weak automorphisms of  $\mathbf{A}$  form a group, which is called the *weak automorphism group* of  $\mathbf{A}$ , and is denoted by  $\text{WAut}(\mathbf{A})$ . It follows immediately from the definitions that for any algebra  $\mathbf{A}$ , the automorphisms of  $\mathbf{A}$  as well as the permutations  $g$  with  $g, g^{-1} \in \text{Clo}_1(\mathbf{A})$  are weak automorphisms of  $\mathbf{A}$ . In fact, it is easy to check that the automorphism group  $\text{Aut}(\mathbf{A})$  of  $\mathbf{A}$  is a normal subgroup of the weak automorphism group  $\text{WAut}(\mathbf{A})$ , and so is the largest subgroup  $\{g \in \mathcal{S}_A : g, g^{-1} \in \text{Clo}_1(\mathbf{A})\}$  of  $\text{Clo}_1(\mathbf{A})$ . If  $\mathbf{A}$  is finite, then the latter group is  $\mathcal{S}_A \cap \text{Clo}_1(\mathbf{A})$ .

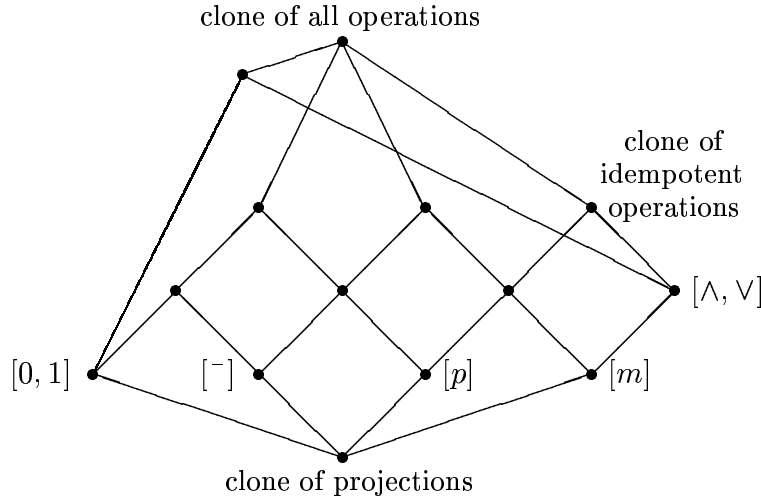
FIGURE 1.  $\mathcal{S}_A$ -closed clones on  $A = \{0, 1\}$ 

For a group  $G \subseteq \mathcal{S}_A$  and a set  $F$  of operations on  $A$  we will say that  $F$  is  $G$ -closed if  $\gamma F = F$  for all  $\gamma \in G$ . In particular, it follows that a clone  $\mathfrak{C}$  on  $A$  is  $G$ -closed if and only if it is fixed by every inner automorphism of the clone lattice that is induced by a permutation from  $G$ , or equivalently,  $\mathfrak{C}$  is  $G$ -closed if and only if  $G$  is a subgroup of the weak automorphism group of the algebra  $\langle A; \mathfrak{C} \rangle$ . Clearly, if  $G$  is the one-element group, then every clone is  $G$ -closed.

**Example 2.1.** On a 2-element set  $A = \{0, 1\}$  the only nontrivial group is  $G = \mathcal{S}_A$ , and the  $\mathcal{S}_A$ -closed clones can be easily determined, using Post's description [36] of all clones. Figure 1 shows the lattice of all these clones. In the diagram  $0, 1, \wedge, \vee, -$  denote the Boolean algebra operations,  $p(x, y, z) = x + y + z$  is the unique minority operation, and  $m(x, y, z) = (x \wedge y) \vee (x \wedge z) \vee (y \wedge z)$  is the unique majority operation on  $A = \{0, 1\}$ .

From now on we will assume that  $A$  is a finite set with at least three elements, and  $A$  is the underlying set of all algebras and clones considered. A relation  $\rho \subseteq A^m$  is called a *compatible relation* of an algebra  $\mathbf{A} = \langle A; F \rangle$  if  $\rho$  is (the underlying set) of a subalgebra of the  $m$ -th direct power  $\mathbf{A}^m$  of  $\mathbf{A}$ . Examples of compatible binary relations include congruences and the graphs of automorphisms. (The *graph* of an  $n$ -ary partial function  $h$  is defined to be the  $(n + 1)$ -ary relation consisting of all tuples  $\langle a_1, \dots, a_n, h(a_1, \dots, a_n) \rangle$  such that  $\langle a_1, \dots, a_n \rangle$  is in the domain of  $h$ .) If  $\rho$  is a compatible relation of the algebra  $\langle A; f \rangle$ , we will also say that  $f$  *preserves*  $\rho$ .

It is well known (see e.g. [34, 35]) that for finite  $A$ , clones on  $A$  can be characterized as the Galois-closed sets of operations in the Galois connection between operations on  $A$  and relations on  $A$  that is defined by the condition “ $f$  preserves  $\rho$ ”. This Galois

connection assigns to every set of operations the collection of all relations that are preserved by every operation in the set, and to every set of relations the collection of all operations that preserve every relation in the set. It is easy to see that Galois-closed sets of operations are clones. The fact that all clones are in fact Galois-closed provided the base set is finite, can be expressed as follows.

**Claim 2.2.** [34, 35] *On a finite base set  $A$ , an operation  $f$  belongs to a clone  $\mathfrak{C}$  if and only if  $f$  preserves all compatible relations of the algebra  $\langle A; \mathfrak{C} \rangle$ .*

For any fixed permutation group  $G \subseteq \mathcal{S}_A$  one can modify this Galois connection so that the Galois-closed sets of operations are exactly the  $G$ -closed clones (cf. e.g. [11]). For any  $\gamma \in \mathcal{S}_A$  and any relation  $\rho \subseteq A^m$  let

$$\gamma\rho = \gamma(\rho) = \{\langle \gamma(x_1), \dots, \gamma(x_m) \rangle : \langle x_1, \dots, x_m \rangle \in \rho\}.$$

Since  $\gamma f$  preserves  $\rho$  for all  $\gamma \in G$  if and only if  $f$  preserves  $\gamma\rho$  for all  $\gamma \in G$ , these two conditions define the same Galois connection, and it follows that the Galois-closed sets of operations in this Galois connection are exactly the  $G$ -closed clones. In other words:

**Claim 2.3.** [11] *On a finite base set  $A$ , either one of the following conditions characterizes  $G$ -closed clones  $\mathfrak{C}$ :*

- (1)  $\gamma f \in \mathfrak{C}$  for every  $f \in \mathfrak{C}$  and  $\gamma \in G$ ;
- (2)  $\gamma\rho$  is a compatible relation of the algebra  $\mathbf{A} = \langle A; \mathfrak{C} \rangle$  for every compatible relation  $\rho$  of  $\mathbf{A}$  and for every  $\gamma \in G$ .

The same argument that proves that clones on a finite set form an atomic and dually atomic, algebraic and dually algebraic lattice, also proves that  $G$ -closed clones form an atomic and dually atomic, algebraic and dually algebraic lattice for all  $G$ . In fact, the lattice of  $G$ -closed clones is a complete sublattice of the lattice of  $H$ -closed clones whenever  $H \subseteq G \subseteq \mathcal{S}_A$ , and in all these lattices the smallest element is the clone of projections, and the largest element is the clone of all operations.<sup>3</sup> One cannot expect that the lattice of  $G$ -closed clones is much simpler than the lattice of all clones, unless the permutation group  $G$  is fairly large.

Next we summarize the notions and basic facts about permutation groups that we will need in this survey. A permutation group  $G \subseteq \mathcal{S}_A$  is called *primitive* if the unary algebra  $\langle A; G \rangle$  is simple, and  $|G| > 1$  when  $|A| = 2$ . For  $1 \leq k \leq |A|$ ,  $G$  is said to be  *$k$ -transitive* if for any two lists  $b_1, \dots, b_k$  and  $c_1, \dots, c_k$  of pairwise distinct elements of  $A$  there exists  $\gamma \in G$  such that  $c_i = \gamma(b_i)$  for all  $i$ ;  $G$  is said

---

<sup>3</sup>This is a consequence of general facts on Galois-closed subrelations that are discussed in the paper [7] in this volume, because the following is true for arbitrary permutation groups  $G, H \subseteq \mathcal{S}_A$ : if  $H \subseteq G$ , then the relation between operations and relations on  $A$  that is defined by the condition “ $\gamma f$  preserves  $\rho$  for all  $\gamma \in G$ ” is a Galois-closed subrelation of the relation defined by the condition “ $\gamma f$  preserves  $\rho$  for all  $\gamma \in H$ ”.

to be *k-homogeneous* if for any two  $k$ -element subsets  $B, C$  of  $A$  there exists  $\gamma \in G$  such that  $C = \gamma(B)$ . A 1-transitive (or equivalently, 1-homogeneous) group is briefly called *transitive*. Clearly, primitive permutation groups are transitive,  $k$ -transitive permutation groups are  $k$ -homogeneous, and  $k$ -homogeneous permutation groups are also  $(|A| - k)$ -homogeneous. It is also easy to see that 2-homogeneous permutation groups are primitive.

The two most well known infinite families of 2-transitive groups are the affine linear groups and the projective linear groups. Let  ${}_{K}\underline{A}$  be a finite vector space with underlying set  $A$ . The automorphism group of  ${}_{K}\underline{A}$  is the *general linear group*  $\mathrm{GL}({}_{K}\underline{A})$ , and its subgroup consisting of all automorphisms with determinant 1 is the *special linear group*  $\mathrm{SL}({}_{K}\underline{A})$ . The *affine general linear group*  $\mathrm{AGL}({}_{K}\underline{A})$  is the subgroup of  $\mathcal{S}_A$  generated by  $\mathrm{GL}({}_{K}\underline{A})$  and by the *group of translations*  $\mathrm{TR}({}_{K}\underline{A}) = \{x + a : a \in A\}$ ;  $\mathrm{AGL}({}_{K}\underline{A})$  is a 2-transitive group on  $A$  for every vector space  ${}_{K}\underline{A}$ . We note that the permutation group  $\mathrm{AGL}({}_{K}\underline{A})$  determines the vector space  ${}_{K}\underline{A}$  up to the choice of 0; equivalently,  $\mathrm{AGL}({}_{K}\underline{A})$  uniquely determines the affine space  ${}_{K}\underline{A}^{\mathrm{id}}$  (see Example 2.11). The *projective general linear group*  $\mathrm{PGL}({}_{K}\underline{A})$  is the quotient of  $\mathrm{GL}({}_{K}\underline{A})$  by its center consisting of all scalar multiplications in  ${}_{K}\underline{A}$ , and  $\mathrm{PSL}({}_{K}\underline{A})$  is its subgroup that arises from  $\mathrm{SL}({}_{K}\underline{A})$  in a similar way; both act 2-transitively on the set of one-dimensional subspaces of  ${}_{K}\underline{A}$  (the points of a projective geometry). If we identify the base set  $A$  of the vector space  ${}_{K}\underline{A}$  with  $K^d$  ( $d = \dim {}_{K}\underline{A}$ ), then each automorphism of the field  $K$  yields a weak automorphism of  ${}_{K}\underline{A}$  by acting coordinatewise on  $A = K^n$  (see the Introduction), and this weak automorphism has a natural permutation action on the set of one-dimensional subspaces of  ${}_{K}\underline{A}$  as well. The permutation group generated by  $\mathrm{AGL}({}_{K}\underline{A})$ , resp.  $\mathrm{PGL}({}_{K}\underline{A})$ , and the corresponding permutations induced by the field automorphisms is denoted by  $\mathrm{AFL}({}_{K}\underline{A})$ , resp.  $\mathrm{PFL}({}_{K}\underline{A})$ . We will omit the subscript  $K$  if  $K$  is a prime field, because then the vector space  ${}_{K}\underline{A}$  is term equivalent to its underlying elementary abelian group  $\underline{A}$ . Clearly, we have  $\mathrm{AFL}(\underline{A}) = \mathrm{AGL}(\underline{A})$  and  $\mathrm{PFL}(\underline{A}) = \mathrm{PGL}(\underline{A})$  in this case. Moreover,  $\mathrm{AFL}({}_{K}\underline{A}) \subseteq \mathrm{AGL}(\underline{A})$  for every vector space  ${}_{K}\underline{A}$  with underlying abelian group  $\underline{A}$ . In statements where the vector space  ${}_{K}\underline{A}$  is relevant up to isomorphism only and  $\dim({}_{K}\underline{A}) = d$ ,  $|K| = q$ , we write  $\mathrm{GL}(d, q)$ ,  $\mathrm{AGL}(d, q)$ ,  $\mathrm{PGL}(d, q)$ , etc., in place of  $\mathrm{GL}({}_{K}\underline{A})$ ,  $\mathrm{AGL}({}_{K}\underline{A})$ ,  $\mathrm{PGL}({}_{K}\underline{A})$ , etc.

The 2-homogeneous permutation groups (on a finite set) are completely classified: a description of 2-homogeneous groups that are not 2-transitive can be found e.g. in [18], Chapter XII, Section 6; the classification of 2-transitive groups, which is based on the classification of finite simple groups, is summarized e.g. in [4]. There are two types of 2-homogeneous groups:

- *Affine 2-homogeneous groups*: these are 2-homogeneous groups  $G$  such that  $\mathrm{TR}(\underline{A}) \subseteq G \subseteq \mathrm{AGL}(\underline{A})$  for some elementary abelian  $p$ -group  $\underline{A}$  ( $p$  prime);  $\mathrm{TR}(\underline{A})$  is the unique minimal normal subgroup of  $G$ .

- *Almost simple 2-transitive groups*: these are 2-transitive permutation groups  $G \subseteq \mathcal{S}_A$  such that  $G$  has a unique minimal normal subgroup  $N$ ,  $N$  is a nonabelian simple group, and — with one exception when  $N$  is primitive but not 2-transitive ( $|A| = 28$ ) —  $N$  is 2-transitive on  $A$ .

After these preparations we will look at some examples of clones that are  $G$ -closed for fairly large permutation groups  $G$ .

**Example 2.4.** Let  $\mathbf{A} = \langle A; T \rangle$  be a unary algebra. Since we are interested in the clone of  $\mathbf{A}$ , we may assume without loss of generality that  $T$  is a submonoid of  $\mathcal{T}_A$ , and hence  $T = \text{Clo}_1(\mathbf{A})$ . Clearly,  $\text{Clo}(\mathbf{A})$  is  $G$ -closed if and only if the group  $P = T \cap \mathcal{S}_A$  of permutations in  $T$  as well as the subsemigroup  $U = T \setminus \mathcal{S}_A$  of nonsurjective transformations in  $T$  are  $G$ -closed. It is easy to see that  $P$  is  $G$ -closed if and only if  $P$  is a normal subgroup of a group  $H \subseteq \mathcal{S}_A$  with  $G \subseteq H$  ( $H$  can be chosen to be  $\text{WAut}(\mathbf{A})$ ).  $G$ -closed semigroups  $U$  of nonsurjective transformations are not so easy to characterize. However, it is easy to verify that if  $G$  is 2-homogeneous and  $U$  is a (nonempty)  $G$ -closed subsemigroup of  $\mathcal{T}_A \setminus \mathcal{S}_A$ , then  $\mathcal{C}_A \subseteq U$ .

These observations apply to the monoid  $T = \mathfrak{C}^{(1)}$  of unary operations of any  $G$ -closed clone  $\mathfrak{C}$ . Thus we get the following.

**Corollary 2.5.** *If  $\mathfrak{C}$  is a  $G$ -closed clone and  $G$  is 2-homogeneous, then one of the following conditions holds:*

- $\mathfrak{C}^{(1)} = \{\text{id}\}$ , that is,  $\mathfrak{C}$  is a clone of idempotent operations;
- $\mathfrak{C}$  contains all constants;
- $\mathfrak{C}^{(1)}$  is a transitive permutation group; in fact,  $\mathfrak{C}^{(1)}$  is a nontrivial normal subgroup of the 2-homogeneous group  $\text{WAut}(\langle A; \mathfrak{C} \rangle)$  containing  $G$ .

In the special case  $G = \mathcal{S}_A$  there is a transparent characterization for the  $G$ -closed transformation monoids. To describe these monoids, define the *type* of an equivalence relation  $\theta$  on  $A$  to be the increasing sequence  $\kappa = (k_1, k_2, \dots, k_r)$  of positive integers that lists the sizes of the  $\theta$ -classes (hence  $k_1 + k_2 + \dots + k_r = |A|$ ). A transformation  $f \in \mathcal{T}_A$  is said to have *kernel type*  $\kappa$  if  $\kappa$  is the type of  $\ker(f)$ . There is a natural partial ordering of kernel types induced by the inclusion ordering of equivalence relations: if  $\kappa$  and  $\lambda$  are kernel types, then  $\kappa \leq \lambda$  exactly when there are equivalence relations  $\theta_\kappa$  and  $\theta_\lambda$  of types  $\kappa$  and  $\lambda$  respectively for which  $\theta_\kappa \subseteq \theta_\lambda$ .

**Theorem 2.6.** [21] *Let  $A$  be a finite set, and let  $U$  be a subsemigroup of  $\mathcal{T}_A \setminus \mathcal{S}_A$ . The following conditions are equivalent:*

- (i)  $U$  is  $\mathcal{S}_A$ -closed;
- (ii) there is a filter  $F$  of kernel types on  $A$  such that the members of  $U$  are exactly the transformations whose kernel types belong to  $F$ .

Combining this theorem with some observations made in Example 2.4 we get the following corollary.

**Corollary 2.7.** *For a finite set  $A$ , a submonoid  $T$  of  $\mathcal{T}_A$  is  $\mathcal{S}_A$ -closed if and only if  $T = P \cup U$ , where  $P$  is one of the permutation groups  $\{\text{id}\}, \mathcal{V}_A$  ( $|A| = 4$ ),  $\mathcal{A}_A$ ,  $\mathcal{S}_A$ , and either  $U = \emptyset$  or  $U$  is a subsemigroup of  $\mathcal{T}_A \setminus \mathcal{S}_A$  that satisfies condition (ii) of Theorem 2.6.*

**Example 2.8.** For  $2 \leq m \leq |A|$  let  $\mathfrak{R}_m$  denote the clone consisting of the projections and all operations whose range has size at most  $m$ . An important subclone of  $\mathfrak{R}_2$  is the following clone  $\mathfrak{B}$ : it consists of the projections and all operations of the form

$$(2.1) \quad \varphi(\varphi_1(x_1) + \cdots + \varphi_n(x_n)) \quad (n \geq 1)$$

where  $\varphi_1, \dots, \varphi_n$  are mappings  $A \rightarrow \{0, 1\}$ ,  $+$  is addition modulo 2, and  $\varphi$  is any mapping  $\{0, 1\} \rightarrow A$ . If  $|A|$  is even, then the projections and all operations of the form (2.1) where the kernel of each  $\varphi_i$  ( $i = 1, \dots, n$ ) has two even size blocks form a proper subclone in  $\mathfrak{B}$ ; this clone will be denoted by  $\mathfrak{B}^*$ . It is easy to check that all the clones  $\mathfrak{R}_m$ ,  $\mathfrak{B}$ , and  $\mathfrak{B}^*$  are  $\mathcal{S}_A$ -closed.

It is well known [3, 22, 37] that the clones containing  $\mathcal{T}_A$  form a chain whose members are exactly the clones  $[\mathcal{T}_A]$ ,  $\mathfrak{B} \cup [\mathcal{T}_A]$ , and  $\mathfrak{R}_m \cup [\mathcal{T}_A]$  ( $m = 2, \dots, |A|$ ). The coatom  $\mathfrak{R}_{|A|-1} \cup [\mathcal{T}_A]$  of this chain is called the *Stupecki clone*. The description of all clones containing  $\mathcal{T}_A$  was extended in [12] to all clones containing  $\mathcal{S}_A$ . Since all clones that contain  $\mathcal{S}_A$  are  $\mathcal{S}_A$ -closed, these results will be covered by the description of  $\mathcal{S}_A$ -closed clones discussed in Section 4.

**Example 2.9.** Another rich class of  $\mathcal{S}_A$ -closed clones is the class consisting of the clones  $\text{Clo}(\mathbf{A})$  where  $\mathbf{A}$  is a *homogeneous algebra*, that is,  $\mathbf{A}$  has  $\mathcal{S}_A$  as its automorphism group. These clones were described in [6] and [23]. The description was extended in [25] to the case when the automorphism group of  $\mathbf{A}$  is  $\mathcal{A}_A$  ( $|A| > 3$ ); interestingly, these clones are also  $\mathcal{S}_A$ -closed.

Examples of homogeneous algebras include the algebras  $\langle A; t \rangle$ ,  $\langle A; d \rangle$ ,  $\langle A; s \rangle$ , and  $\langle A; \ell_i \rangle$  ( $i = 3, \dots, |A|$ ) whose operations are defined as follows:

$$t(x, y, z) = \begin{cases} z & \text{if } x = y, \\ x & \text{if } x \neq y, \end{cases} \quad d(x, y, z) = \begin{cases} x & \text{if } x = y, \\ z & \text{if } x \neq y, \end{cases} \quad s(x, y, z) = \begin{cases} z & \text{if } x = y, \\ y & \text{if } x = z, \\ x & \text{otherwise,} \end{cases}$$

and

$$\ell_i(x_1, \dots, x_i) = \begin{cases} x_i & \text{if } x_1, \dots, x_i \text{ are pairwise distinct,} \\ x_1 & \text{otherwise.} \end{cases}$$

The operation  $t$  is called the *ternary discriminator*, and  $d$  is called the *dual discriminator*. Note that on the 2-element set  $A = \{0, 1\}$ ,  $s$  coincides with the operation  $x + y + z$  and  $d$  coincides with the majority operation  $m$  from Example 2.1.



**Example 2.10.** Let  $\mathbf{A}$  be a *quasiprimal* algebra, that is, a finite algebra such that  $t$  is a term operation of  $\mathbf{A}$ . Equivalently,  $\mathbf{A}$  is quasiprimal if and only if every operation on  $A$  that preserves the isomorphisms between subalgebras of  $\mathbf{A}$  is a term operation of  $\mathbf{A}$ . Isomorphisms between subalgebras are briefly called *internal isomorphisms*. Suppose that  $\text{WAut}(\mathbf{A})$  is 2-homogeneous and  $\mathbf{A}$  is not idempotent. If  $\text{Clo}(\mathbf{A})$  contains all constants, then  $\mathbf{A}$  has no proper subalgebras and no nontrivial automorphisms, therefore  $\mathbf{A}$  is primal and  $\text{WAut}(\mathbf{A}) = \mathcal{S}_A$ . In view of Corollary 2.5 the only remaining possibility is that  $\text{Clo}_1(\mathbf{A})$  is a transitive normal subgroup of  $\text{WAut}(\mathbf{A})$ . The transitivity of  $\text{Clo}_1(\mathbf{A})$  implies that  $\mathbf{A}$  has no proper subalgebras, therefore the only internal isomorphisms of  $\mathbf{A}$  are its automorphisms. The automorphism group  $\text{Aut}(\mathbf{A})$  of  $\mathbf{A}$  cannot be trivial, because  $\mathbf{A}$  is not primal. Therefore  $\text{Aut}(\mathbf{A})$  is also a transitive normal subgroup of  $\text{WAut}(\mathbf{A})$ . Hence the classification of 2-homogeneous groups shows that, for some elementary abelian  $p$ -group ( $p$  prime), we have  $\text{Clo}_1(\mathbf{A}) = \text{TR}(\underline{A}) = \text{Aut}(\mathbf{A})$  and  $\text{WAut}(\mathbf{A}) \subseteq \text{AGL}(\underline{A})$ . It follows that  $\mathbf{A}$  is term equivalent to  $\langle A; t, \text{TR}(\underline{A}) \rangle$ , because both algebras are quasiprimal and they have the same internal isomorphisms. Thus every permutation from  $\text{AGL}(\underline{A})$  is a weak automorphism of  $\mathbf{A}$ , so  $\text{WAut}(\mathbf{A}) = \text{AGL}(\underline{A})$  holds in this case.

**Example 2.11.** An algebra  $\mathbf{A}$  is called *affine* if for some ring  $R$  there exists a module  ${}_R\underline{A}$  on the universe  $A$  of  $\mathbf{A}$  such that  $\mathbf{A}$  is polynomially equivalent to  ${}_R\underline{A}$ . It can be proved that in this case  $\mathbf{A}$  has the same idempotent term operations as the *affine module*  ${}_R\underline{A}^{\text{id}} = \langle A; x - y + z, \{rx + (1 - r)y : r \in R\} \rangle$ . In particular,  $x - y + z$  is a term operation of  $\mathbf{A}$ . Now we will look at two important classes of affine algebras, and determine the weak automorphism groups of these algebras. One class consists of those finite affine algebras that are polynomially equivalent to some vector space  ${}_K\underline{A}$ , and the other consists of all finite simple affine algebras. If  $\mathbf{A}$  is a finite simple affine algebra, then  $\mathbf{A}$  is polynomially equivalent to a finite simple module; up to term equivalence, a finite simple module is of the form  ${}_R\underline{A}$  where  $R = \text{End}({}_K\underline{A})$  and  ${}_K\underline{A}$  is a vector space.

Thus, let us assume that  $\mathbf{A}$  is polynomially equivalent to a module  ${}_R\underline{A}$  where  $R = K$  or  $R = \text{End}({}_K\underline{A})$  for a finite vector space  ${}_K\underline{A}$ . Since  $x - y + z$  is the only Mal'tsev operation in the clone of  $\mathbf{A}$ , it must be conjugated to itself by every  $\gamma \in \text{WAut}(\mathbf{A})$ . Thus  $\text{WAut}(\mathbf{A}) \subseteq \text{Aut}(\langle A; x - y + z \rangle) = \text{Aut}(\underline{A}^{\text{id}}) = \text{AGL}(\underline{A})$ . In the case when  $R = K$ , the set of binary idempotent term operations of  $\mathbf{A}$  is  $\{g_k : k \in K\}$  where  $g_k(x, y) = kx + (1 - k)y$ ; this set is closed under conjugation by all  $\gamma \in \text{WAut}(\mathbf{A})$ , therefore we get that  $\text{WAut}(\mathbf{A}) \subseteq \text{AFL}({}_K\underline{A})$ . In the case when  $R = \text{End}({}_K\underline{A})$ , those ternary compatible relations of  $\mathbf{A}$  that are graphs of binary idempotent operations on  $A$  are exactly the graphs of the operations  $g_k$  ( $k \in K$ ); by Claim 2.3 this set of compatible relations is closed under conjugation by all  $\gamma \in \text{WAut}(\mathbf{A})$ , hence we conclude again that  $\text{WAut}(\mathbf{A}) \subseteq \text{AFL}({}_K\underline{A})$ .

Now suppose that the weak automorphism group of  $\mathbf{A}$  is 2-homogeneous. If  $\mathbf{A}$  is idempotent, then it follows from our general remarks about affine algebras that  $\mathbf{A}$  is term equivalent to  $RA^{\text{id}}$ . If  $\text{Clo}(\mathbf{A})$  contains all constants, then by definition  $\mathbf{A}$  is term equivalent to  $RA^{\text{c}}$ . According to Corollary 2.5, there is only one more possibility, namely that  $\text{Clo}_1(\mathbf{A})$  is a transitive permutation group. Since  $ux + a \in \text{Clo}_1(\mathbf{A})$  implies  $r(ux + a) + (1 - r)x = (1 - r(1 - u))x + ra \in \text{Clo}_1(\mathbf{A})$  for all  $r \in R$  and some of these operations are not permutations unless  $u = 1$ , we get that  $\text{Clo}_1(\mathbf{A}) \subseteq \text{TR}(\underline{A})$ . As  $\text{Clo}_1(\mathbf{A})$  is transitive, equality holds. Hence  $\mathbf{A}$  is term equivalent to the algebra  $RA^{\text{tr}}$  that we get from  $RA^{\text{id}}$  by adding all translations from  $\text{TR}(\underline{A})$  as basic operations. It is straightforward to check that whether  $\mathbf{A}$  is term equivalent to  $RA^{\text{id}}$  or  $RA^{\text{c}}$  or  $RA^{\text{tr}}$ , every permutation from  $\text{AFL}(K\underline{A})$  is a weak automorphism. Thus  $\text{WAut}(\mathbf{A}) = \text{AFL}(K\underline{A})$ .

**Example 2.12.** The  $m$ -th matrix power of an algebra  $\mathbf{B}$ , denoted  $\mathbf{B}^{[m]}$ , is the algebra on the underlying set  $B^m$  whose operations are the following: (i) all term operations of the  $m$ -th direct power of  $\mathbf{B}$ , (ii) the *diagonal operation*  $\Delta$  defined by

$$\Delta(\langle x_{1i} \rangle_{i=1}^m, \dots, \langle x_{mi} \rangle_{i=1}^m) = \langle x_{11}, \dots, x_{mm} \rangle,$$

and (iii) for each permutation  $\pi \in \mathcal{S}_m$ , the unary operation  $u_\pi: B^m \rightarrow B^m$  that permutes the coordinates of  $B^m$  according to  $\pi$ .

If  $\mathbf{B}$  is a nontrivial unary algebra, then every term operation of  $\mathbf{B}^{[m]}$  depends on at most  $m$  variables, and the  $m$ -ary idempotent term operations of  $\mathbf{B}^{[m]}$  that depend on all variables are exactly the operations that arise from  $\Delta$  by permuting variables. Therefore this set of operations is closed under conjugation by all permutations  $\gamma \in \text{WAut}(\mathbf{B}^{[m]})$ . This implies that  $\text{WAut}(\mathbf{B}^{[m]}) \subseteq \mathcal{S}_B \text{Wr } \mathcal{S}_m$ , the *wreath product* of  $\mathcal{S}_B$  and  $\mathcal{S}_m$  (with the product action), which is the subgroup of  $\mathcal{S}_{B^m}$  generated by all permutations  $\gamma_1 \times \dots \times \gamma_m$  ( $\gamma_i \in \mathcal{S}_B$ ) acting coordinatewise, and all  $u_\pi$  ( $\pi \in \mathcal{S}_m$ ) that permute the coordinates. It is not hard to show that the permutation group  $\mathcal{S}_B \text{Wr } \mathcal{S}_m$  is not 2-homogeneous on  $B^m$  if  $|B| \geq 2$  and  $m \geq 2$ . Thus, for a nontrivial unary algebra  $\mathbf{B}$ ,  $\text{WAut}(\mathbf{B}^{[m]})$  is not 2-homogeneous unless  $m = 1$ .

### 3. $G$ -CLOSED CLONES WHEN $G$ IS 2-HOMOGENEOUS

In [38] L. Szabó classified all finite algebras  $\mathbf{A}$  such that  $\mathbf{A}$  expanded with its weak automorphisms is simple. This class includes every algebra whose weak automorphism group is primitive. The classification is more transparent when the weak automorphism group is assumed to be 2-transitive (Theorem 5.6 in [38]). In this section we discuss this result and sketch its proof which nicely combines methods from clone theory and tame congruence theory. The extraction of a direct proof for the 2-transitive case reveals that for the classification in Theorem 5.6 of [38] it suffices to assume the slightly weaker condition that the weak automorphism group is 2-homogeneous.

A remarkable consequence of this classification is an explicit description of all maximal  $G$ -closed clones when  $G$  is 2-homogeneous. In particular, we will see that for all 2-homogeneous permutation groups  $G$  that are not contained in an affine group  $\text{AGL}(d, p)$ , there are exactly two maximal  $G$ -closed clones: the clone of idempotent operations and the Słupecki clone. The maximal  $G$ -closed clones were determined earlier by Hoa [16] and Marchenkov [26] under much stronger transitivity assumptions on  $G$ ; their assumptions imply  $k$ -homogeneity for every  $k$  ( $1 \leq k \leq |A|$ ); cf. Theorem 5.2.

**Theorem 3.1.** [38] *Let  $\mathbf{A}$  be a finite algebra with at least three elements. If the weak automorphism group of  $\mathbf{A}$  is 2-homogeneous, then one of the following conditions holds for  $\mathbf{A}$ :*

- (O)  $\mathbf{A}$  is a primal algebra;
- (I)  $\mathbf{A}$  is a simple idempotent algebra that is not affine;
- (U)  $\mathbf{A}$  is an essentially unary algebra that is term equivalent to  $\langle A; M \rangle$  or  $\langle A; M \rangle^c$  where  $M$  is a normal subgroup of a 2-homogeneous permutation group on  $A$ ;
- (S)  $\mathbf{A}$  is a simple algebra such that  $\text{Clo}(\mathbf{A})$  is contained in the Słupecki clone, and contains a unary operation that is neither constant nor a permutation;
- (A)  $\mathbf{A}$  is an affine algebra; namely  $\mathbf{A}$  is term equivalent to one of the algebras  ${}_R\underline{A}^{\text{id}}$ ,  ${}_R\underline{A}^{\text{tr}}$ , or  ${}_R\underline{A}^c$  (see Example 2.11) where  $\underline{A}$  is an elementary abelian group on  $A$  and for a subfield  $K$  of  $\text{End}(\underline{A})$ , either  $R = K$  or  $R = \text{End}(K\underline{A})$ ;
- (Q)  $\mathbf{A}$  is a quasiprimal algebra that is term equivalent to  $\langle A; t, \text{TR}(\underline{A}) \rangle$  for some elementary abelian group  $\underline{A}$ .

This theorem allows us to determine the coarse structure of the lattice of  $G$ -closed clones for any 2-homogeneous permutation group  $G$ . For a given 2-homogeneous permutation group  $G$ , the lattice of  $G$ -closed clones consists of all clones  $\mathfrak{C} = \text{Clo}(\mathbf{A})$  where  $\mathbf{A}$  is one of the algebras listed in the theorem such that  $G \subseteq \text{WAut}(\mathbf{A})$ . Figure 2 displays this lattice, and indicates the types of the clones according to Theorem 3.1. In Figure 2 clones of types (A) and (Q) are denoted by circles, and all other clones by bullets. This distinction is made to emphasize that  $G$ -closed clones of types (A) and (Q) exist if and only if  $G \subseteq \text{AGL}(d, p)$  for some prime  $p$ . This follows from Examples 2.10 and 2.11, because if  $\mathbf{A}$  is as in (A), then  $\text{WAut}(\mathbf{A}) \subseteq \text{AGL}(\underline{A})$ , and equality holds for at least one  $\mathbf{A}$  in (A), while if  $\mathbf{A}$  is as in (Q), then  $\text{WAut}(\mathbf{A}) = \text{AGL}(\underline{A})$ .

Therefore, if  $G$  is not contained in any affine linear group  $\text{AGL}(d, p)$  ( $p$  prime), then the lattice of  $G$ -closed clones looks much simpler than Figure 2: all circles and adjacent lines can be deleted. In particular, we see that there are exactly two maximal  $G$ -closed clones: the clone of idempotent operations and the Słupecki clone.

Next assume that  $G$  is a subgroup of an affine linear group  $\text{AGL}(d, p)$  and contains the translation subgroup  $\text{TR}(d, p)$  of  $\text{AGL}(d, p)$ . Then, up to the choice of 0, there is a unique elementary abelian  $p$ -group  $\underline{A}$  such that  $\text{TR}(\underline{A}) \subseteq G \subseteq \text{AGL}(\underline{A})$ . Hence

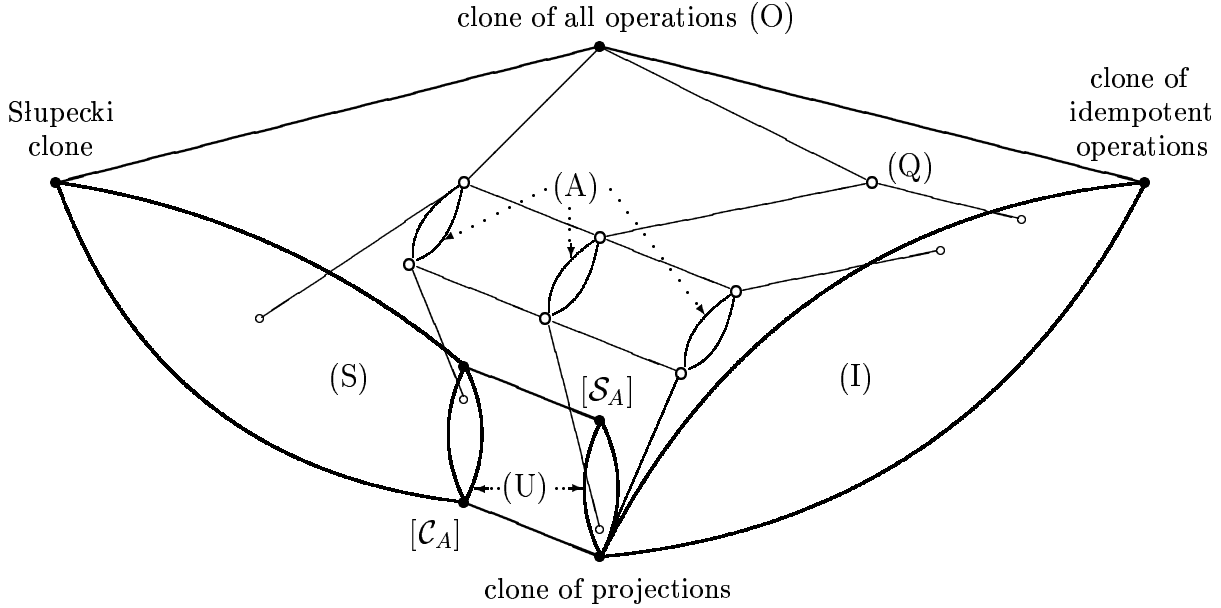

FIGURE 2.  $G$ -closed clones on  $A$  ( $|A| \geq 3$ ) for 2-homogeneous  $G$

there is a unique  $G$ -closed clone of type (Q), and a unique family of  $G$ -closed clones of type (A), which form three disjoint intervals

$$(3.1) \quad [\text{Clo}(\underline{A}^{\text{id}}), \text{Clo}({}_E\underline{A}^{\text{id}})], \quad [\text{Clo}(\underline{A}^{\text{tr}}), \text{Clo}({}_E\underline{A}^{\text{tr}})], \quad [\text{Clo}(\underline{A}^c), \text{Clo}({}_E\underline{A}^c)] \\ (E = \text{End}(\underline{A}))$$

as depicted in Figure 2, and each interval is isomorphic to the lattice of all subrings  $R$  of  $\text{End}(\underline{A})$  such that either  $R = K$  or  $R = \text{End}({}_K\underline{A})$  for a subfield  $K$  of  $\text{End}(\underline{A})$  with  $G \subseteq \text{AGL}({}_K\underline{A})$ . So, in this case, there are exactly four maximal  $G$ -closed clones.

Finally, it remains to consider the case when  $G$  is a 2-homogeneous permutation group such that  $G \subseteq \text{AGL}(d, p)$  for some  $d$  and some prime  $p$ , but the normal subgroup  $G \cap \text{TR}(d, p)$  of  $G$  is trivial. I am indebted to P. P. Pálffy for pointing out that in this case  $G$  cannot be of affine type, and if  $G$  is an almost simple 2-transitive permutation group, then the classification of these groups can be used to show that the only possibility for  $G$  and  $\text{AGL}(d, p)$  is the following:  $|A| = 8$ ,  $G = \text{PSL}(2, 7)$ , and  $d = 3$ ,  $p = 2$ . It is not hard to check that if we are given a 2-homogeneous group  $G = \text{PSL}(2, 7)$  on an 8-element set  $A$ , then there are two essentially different elementary 2-groups  $\underline{A}$  on  $A$  such that  $G \subseteq \text{AGL}(\underline{A})$ . Hence there are two  $G$ -closed clones of type (Q), and two disjoint families of  $G$ -closed clones of type (A). It follows, in particular, that there are exactly six maximal  $G$ -closed clones.

*Sketch of proof of Theorem 3.1.* Let  $\mathbf{A}$  be a finite algebra such that  $|A| \geq 3$  and  $G = \text{WAut}(\mathbf{A})$  is 2-homogeneous. Assume first that  $\mathbf{A}$  is not simple, and let  $\theta(u, v)$  ( $u \neq v$ ) be a minimal congruence of  $\mathbf{A}$ . Since  $G = \text{WAut}(\mathbf{A})$  is 2-homogeneous, every nontrivial principal congruence of  $\mathbf{A}$  is of the form  $\theta(\gamma(u), \gamma(v)) = \gamma(\theta(u, v))$  for some  $\gamma \in G$ , and is therefore a minimal congruence. Suppose  $\mathbf{A}$  has a unary polynomial operation  $f \in \text{Pol}_1(\mathbf{A})$  which is neither a permutation nor a constant. Let  $B$  be a nonsingleton kernel class of  $f$ ,  $b \in B$  a fixed element, and let  $C = A \setminus B$ . Then for any  $b' \in B \setminus \{b\}$  and  $c \in C$  we have  $\theta(f(b), f(c)) = \theta(f(b'), f(c)) \subseteq \theta(b, c) \cap \theta(b', c)$  and  $\theta(b, b') \subseteq \theta(b, c) \vee \theta(b', c)$ ; hence the minimality of the principal congruences implies first that  $\theta(b, c) = \theta(b', c)$  and then that  $\theta(b, c) = \theta(b, b')$ . Since this equality holds for all  $b' \in B \setminus \{b\}$  and  $c \in C$ , we see that the minimal congruence  $\theta(b, x)$  ( $x \in A \setminus \{b\}$ ) is independent of  $x$ , and is therefore the full relation. Thus  $\mathbf{A}$  is simple, which contradicts our assumption. This proves that every unary polynomial operation of  $\mathbf{A}$  is a permutation or a constant. Hence we can apply Pálffy's Theorem:

**Theorem 3.2.** [33] *If  $\mathbf{A}$  is a finite algebra with at least three elements such that every unary polynomial operation of  $\mathbf{A}$  is a permutation or a constant, then either  $\mathbf{A}$  is essentially unary or  $\mathbf{A}$  is polynomially equivalent to a vector space.*

Thus,  $\mathbf{A}$  satisfies condition (U) (see Example 2.4) or condition (A) with  $R = K$  (see Example 2.11).

From now on we will assume that  $\mathbf{A}$  is simple. If  $\mathbf{A}$  is an idempotent algebra, then either (I) holds, or  $\mathbf{A}$  is a simple idempotent affine algebra. Applying again the facts established in Example 2.11 we get that  $\mathbf{A}$  is term equivalent to  ${}_R \underline{A}^{\text{id}}$  with  $R = \text{End}({}_K A)$  as in (A).

Assume now that  $\mathbf{A}$  is simple and not idempotent. Let  $\mathfrak{C} = \text{Clo}(\mathbf{A})$ . It follows from Corollary 2.5 that either  $\mathfrak{C}^{(1)}$  is a transitive permutation group, or  $\mathfrak{C}^{(1)}$  contains all constants. In either case,  $\mathbf{A}$  has no proper subalgebras, therefore we can apply the following strengthening of Rosenberg's Primal Algebra Characterization Theorem:

**Theorem 3.3.** [40, 41] *Let  $\mathbf{A}$  be a finite simple algebra with no proper subalgebras. Then one of the following conditions holds for  $\mathbf{A}$ :*

- (a)  $\mathbf{A}$  is quasiprimal;
- (b)  $\mathbf{A}$  is affine;
- (c)  $\mathbf{A}$  is isomorphic to an algebra term equivalent to  $\mathbf{U}^{[m]}$  for some 2-element unary algebra  $\mathbf{U}$  and some integer  $m \geq 1$ ;
- (d)  $\mathbf{A}$  has a compatible  $k$ -regular relation ( $k \geq 3$ );
- (e)  $\mathbf{A}$  has a  $k$ -ary compatible central relation ( $k \geq 2$ );
- (f)  $\mathbf{A}$  has a compatible bounded partial order.

Moreover, if all fundamental operations of  $\mathbf{A}$  are surjective, then (a), (b), or the following condition holds for  $\mathbf{A}$ :

(c)'  $\mathbf{A}$  is isomorphic to an algebra term equivalent to  $(U; \Gamma)^{[m]}$  for some finite set  $U$  ( $|U| \geq 2$ ), some  $m \geq 1$ , and for some permutation group  $\Gamma$  on  $U$  which acts primitively on  $U$ .

For the precise definition of a  $k$ -regular relation the reader is referred to [40, 41] or [35]. To be able to follow the rest of the proof it suffices to know that every  $k$ -regular relation is a  $k$ -ary totally reflexive, totally symmetric relation  $\rho$  which is distinct from the full relation  $A^k$ ; here *totally reflexive* means that  $\rho$  contains all  $n$ -tuples whose coordinates are not pairwise distinct, and *totally symmetric* means that  $\rho$  is invariant under permuting coordinates. A  $k$ -ary *central relation* is a totally reflexive, totally symmetric relation  $\rho \neq A^k$  such that  $\{c\} \times A^{n-1} \subseteq \rho$  for at least one  $c \in A$ .

Now we apply Theorem 3.3. In the case when  $\mathfrak{C}^{(1)}$  is a transitive permutation group, every term operation of  $\mathbf{A}$  is surjective. Therefore condition (a), (b), or (c)' holds for  $\mathbf{A}$ . In fact, (c)' can hold only if  $m = 1$ , because otherwise  $\text{WAut}(\mathbf{A})$  is not 2-homogeneous by Example 2.12. If (c)' holds with  $m = 1$ , then  $\mathbf{A}$  is essentially unary, so  $\mathbf{A}$  satisfies condition (U) by Example 2.4. If (b) holds, then by Example 2.11,  $\mathbf{A}$  must be term equivalent to  ${}_R \underline{A}^{\text{tr}}$  with  $R = \text{End}({}_K \underline{A})$  as in (A). If (a) holds, then by Example 2.10,  $\mathbf{A}$  must satisfy condition (Q).

It remains to consider the case when  $\mathbf{A}$  is simple and  $\mathfrak{C}^{(1)}$  contains all constants. The latter condition means that  $\mathbf{A}$  is term equivalent to  $\mathbf{A}^c$ . This is a perfect setting for applying tame congruence theory. In fact, we need only a very small portion of the theory which we summarize now.

For a finite algebra  $\mathbf{A}$  and for  $e \in \text{Pol}_1(\mathbf{A})$  we call  $e$  an *idempotent unary polynomial* of  $\mathbf{A}$  if  $e^2 = e$ , and we call  $e$  a *minimal idempotent polynomial* of  $\mathbf{A}$  if it is an idempotent unary polynomial which is not constant, and has minimal range (with respect to inclusion) among the nonconstant idempotent unary polynomials of  $\mathbf{A}$ .<sup>4</sup> The range  $e(A)$  of a minimal idempotent of  $\mathbf{A}$  is called a *minimal set*; if  $\mathbf{A}$  is simple, then it can also be called a *trace*. For any idempotent unary polynomial  $e$  of  $\mathbf{A}$  we define the *induced algebra* on the range  $N = e(A)$  of  $e$  as follows:

$$\mathbf{A}|_N = \langle N; \{ep|_N : p \in \text{Pol}(\mathbf{A})\} \rangle.$$

If  $e, e'$  are idempotent unary polynomials of  $\mathbf{A}$ , we say that the sets  $N = e(A)$  and  $N' = e'(A)$  are *polynomially isomorphic* if there exist unary polynomials  $g, h \in \text{Pol}_1(\mathbf{A})$  such that  $g$  maps  $N$  onto  $N'$ ,  $h$  maps  $N'$  onto  $N$ , and  $hg|_N = \text{id}_N$ ,  $gh|_{N'} = \text{id}_{N'}$ ;  $g, h$  are called *polynomial isomorphisms*.

**Theorem 3.4.** [17] *Let  $\mathbf{A}$  be a finite simple algebra.*

- (1) *For every minimal idempotent polynomial  $e$  of  $\mathbf{A}$ , the induced algebra  $\mathbf{A}|_N$  on  $N = e(A)$  is polynomially equivalent to one of the following algebras:*

---

<sup>4</sup>Notice that in this context the word ‘idempotent’ is applied to unary operations only, and has a different meaning than in the definition of an idempotent operation, as introduced at the beginning of Section 2.

1. a simple unary algebra  $\langle N; \Gamma \rangle$  where  $\Gamma \subseteq \mathcal{S}_N$  is a group;
  2. a one-dimensional vector space on  $N$ ;
  3. a 2-element Boolean algebra ( $|N| = 2$ );
  4. a 2-element lattice ( $|N| = 2$ );
  5. a 2-element semilattice ( $|N| = 2$ ).
- (2) Any two traces of  $\mathbf{A}$  are polynomially isomorphic.

It is easy to see that if for two idempotent unary polynomials  $e, e'$  of  $\mathbf{A}$  the sets  $N = e(A)$  and  $N' = e'(A)$  are polynomially isomorphic, then the induced algebras  $\mathbf{A}|_N$  and  $\mathbf{A}|_{N'}$  have isomorphic clones. Therefore the type 1–5 of  $\mathbf{A}|_N$  ( $N = e(A)$ ) in Theorem 3.4 is independent of the choice of the minimal idempotent polynomial  $e$  of  $\mathbf{A}$ ; this number is called the *type* of the finite simple algebra  $\mathbf{A}$ .

Now let us return to the proof of Theorem 3.1 in the case when  $\mathbf{A}$  is simple and  $\mathfrak{C}^{(1)}$  contains all constants. We can apply Theorem 3.3 to  $\mathbf{A}$ . We will look at cases (a)–(f) separately. If  $\mathbf{A}$  is quasiprimal, then  $\mathbf{A}$  must be primal as  $\mathfrak{C}^{(1)}$  contains all constants; hence (O) holds for  $\mathbf{A}$ . If  $\mathbf{A}$  is affine, then  $\mathfrak{C} = \text{Clo}(\mathbf{A}) = \text{Pol}(\mathbf{A})$  is the polynomial clone of a finite simple module; therefore, by Example 2.11,  $\mathbf{A}$  must be term equivalent to  ${}_R\mathbf{A}^c$  with  $R = \text{End}({}_K\mathbf{A})$  as in (A). Case (c) cannot hold for  $\mathbf{A}$ ; otherwise our assumption that  $|A| \geq 3$  would imply  $m > 1$ , but then by Example 2.12 the weak automorphism group of  $\mathbf{U}^{[m]}$  is not 2-homogeneous. Hence we are left with the cases when one of conditions (d), (e), or (f) holds for  $\mathbf{A}$ . Note that in these cases  $\mathbf{A}$  cannot be affine or quasiprimal.

Next we show that  $\mathbf{A}$  cannot have a binary compatible central relation or a non-trivial compatible partial order. Suppose first that  $\rho$  is a binary compatible central relation of  $\mathbf{A}$ , and select  $c \in A$  so that  $\{c\} \times A \subseteq \rho$ . Let  $e = e^2 \in \mathfrak{C}^{(1)}$  be a minimal idempotent polynomial of  $\mathbf{A}$ , and let  $N = e(A)$ . Then  $e(\rho) = \rho|_N$  is a compatible relation of the induced algebra  $\mathbf{A}|_N$  such that  $e(\rho)$  is reflexive and symmetric. Moreover, since  $\{c\} \times A \subseteq \rho$ , an application of  $e$  shows that  $\{e(c)\} \times e(A) \subseteq e(\rho)$ . Thus  $e(\rho)$  is either the full relation or it is a compatible central relation of  $\mathbf{A}|_N$ . However, none of the algebras listed in Theorem 3.4 (1) admit compatible central relations. Therefore  $e(\rho)$  is the full relation for every minimal idempotent polynomial  $e$  of  $\mathbf{A}$ . Since the weak automorphism group  $G$  of  $\mathbf{A}$  is 2-homogeneous and every conjugate  $\gamma e$  ( $\gamma \in G$ ) of a minimal idempotent polynomial  $e$  of  $\mathbf{A}$  is again a minimal idempotent polynomial of  $\mathbf{A}$ , we conclude that  $\rho$  contains every pair from  $A$ . This contradicts our assumption that  $\rho$  is central, and hence proves that  $\mathbf{A}$  does not have a compatible binary central relation.

Suppose now that  $\mathbf{A}$  has a nontrivial compatible partial order, and let  $\rho$  be a minimal such order. As before, for every minimal idempotent polynomial  $e$  of  $\mathbf{A}$ ,  $e(\rho) = \rho|_N$  is a compatible relation of the induced algebra  $\mathbf{A}|_N$ . Clearly,  $e(\rho) = \rho|_N$  is a partial order on  $N$ . Assume  $e(\rho) = \rho|_N$  is trivial (i.e., the equality relation). Then  $\rho \subseteq \ker(e)$ ; hence the symmetric transitive closure of  $\rho$  is a nontrivial congruence of

$\mathbf{A}$ , which is impossible, as  $\mathbf{A}$  is simple. Thus  $e(\rho)$  is a nontrivial compatible partial order of  $\mathbf{A}|_N$ . Among the algebras listed in Theorem 3.4 (1) only some of the 2-element algebras admit nontrivial compatible partial orders. Hence  $N$  is a 2-element set, and the two elements of  $N$  are comparable with respect to  $\rho$ . Since the weak automorphism group  $G$  of  $\mathbf{A}$  is 2-homogeneous and every conjugate  $\gamma e$  ( $\gamma \in G$ ) of a minimal idempotent polynomial  $e$  of  $\mathbf{A}$  is again a minimal idempotent polynomial of  $\mathbf{A}$ , we conclude that any two elements of  $\mathbf{A}$  are comparable with respect to  $\rho$ . Thus  $\langle A; \rho \rangle$  is a chain. As  $\rho$  was chosen to be a minimal nontrivial compatible partial order of  $\mathbf{A}$ , every  $\gamma\rho$  ( $\gamma \in G$ ) is a minimal nontrivial compatible partial order of  $\mathbf{A}$ . This implies that  $\gamma\rho = \rho$  or  $\gamma\rho = \rho^{-1}$  holds for all  $\gamma \in G$ . Since  $\langle A; \rho \rangle$  is a chain with more than two elements,  $G$  cannot be transitive. This contradiction proves that  $\mathbf{A}$  has no nontrivial compatible partial order.

Thus  $\mathbf{A}$  has a compatible  $k$ -ary regular or central relation  $\rho$  with  $k \geq 3$ . Let  $\sigma = \bigcap (\gamma\rho : \gamma \in G)$ . Clearly,  $\sigma$  is a  $k$ -ary totally reflexive, totally symmetric compatible relation of  $\mathbf{A}$ . Moreover, by construction,  $\gamma\sigma = \sigma$  for all  $\gamma \in G$ . Let  $\mathbf{A}^*$  denote the algebra with underlying set  $A$  whose operations are the surjective term operations of  $\mathbf{A}$  and the permutations from  $G$ . The properties of  $\sigma$  ensure that  $\sigma$  is a compatible relation of  $\mathbf{A}^*$ . Moreover, by definition, the fundamental operations of  $\mathbf{A}$  are surjective, and because of  $G \subseteq \text{Clo}(\mathbf{A}^*)$ , the algebra  $\mathbf{A}^*$  is simple and has no proper subalgebras. Therefore conditions (a), (b), or (c)' from Theorem 3.3 hold for  $\mathbf{A}^*$  in place of  $\mathbf{A}$ . Since  $\mathbf{A}^*$  has a totally reflexive, totally symmetric compatible relation of arity  $\geq 3$ ,  $\mathbf{A}^*$  is neither quasiprimal nor affine. Thus (c)' must hold for  $\mathbf{A}^*$ . Since the permutations from  $G$  are weak automorphisms of  $\mathbf{A}^*$ , it follows from Example 2.12 that  $m = 1$ , that is, the algebra  $\mathbf{A}^*$  is essentially unary. The definition of  $\mathbf{A}^*$  shows now that every surjective term operation of  $\mathbf{A}$  is essentially unary, that is, the clone of  $\mathbf{A}$  is contained in the Słupecki clone. Since all constants are term operations of  $\mathbf{A}$  and  $\mathbf{A}$  is simple, we get that (S) holds for  $\mathbf{A}$  unless every unary term operation of  $\mathbf{A}$  is constant or a permutation. In the latter case Theorem 3.2, combined with the fact that  $\mathbf{A}$  is not affine, yields that  $\mathbf{A}$  satisfies condition (U) (cf. also Example 2.4). This completes the proof of Theorem 3.1.  $\square$

**Remark 3.5.** (1) Every algebra  $\mathbf{A}$  that satisfies the assumptions of Theorem 3.1 and condition (I) is functionally complete, and hence is simple of type **3**. To verify that  $\mathbf{A}$  is functionally complete, observe that every weak automorphism of  $\mathbf{A}$  is a weak automorphism of the algebra  $\mathbf{A}^c$  as well; now, if we apply Theorem 3.1 to the algebra  $\mathbf{A}^c$ , we see that none of the conditions can hold for  $\mathbf{A}^c$  except (O), hence  $\mathbf{A}^c$  is primal.

(2) Every algebra  $\mathbf{A}$  that satisfies the assumptions of Theorem 3.1 and condition (S) is of type **1**, **2**, or **3**. This follows from the fact that every simple algebra of type **4** or **5** has a connected compatible partial order (see Theorem 5.26 in [17]); however, in the course of proving Theorem 3.1 we saw that if an algebra  $\mathbf{A}$  satisfies



the assumptions of the theorem and the additional conditions that  $\mathbf{A}$  is simple and  $\mathcal{C}_A \subseteq \text{Clo}(\mathbf{A})$ , then  $\mathbf{A}$  has no nontrivial compatible partial order.

#### 4. $\mathcal{S}_A$ -CLOSED CLONES

In this section we give a complete description of the  $\mathcal{S}_A$ -closed clones on a finite set  $A$ . The case  $|A| = 2$  was discussed in Example 2.1, so we will assume throughout this section that  $A$  has at least three elements. The description of  $\mathcal{S}_A$ -closed clones for  $|A| = 3$  was first published in [13]. As regards the case  $|A| \geq 4$ , in [14] Hoa found the maximal  $\mathcal{S}_A$ -closed clones and described all  $\mathcal{S}_A$ -closed clones that are contained in the Slupecki clone; in [15] he announced the completion of the description of all  $\mathcal{S}_A$ -closed clones. Later Marchenkov [27, 28] used a purely relational approach to describe all  $\mathcal{S}_A$ -closed clones that are not contained in the Slupecki clone. The description we present here is similar to Hoa's and Marchenkov's. However, the proof we will outline differs essentially from the earlier proofs: we will combine arguments with operations and relations, and will make essential use of some ideas and results of tame congruence theory.

Clearly,  $\mathcal{S}_A$  is a 2-homogeneous group. Therefore we can start our search for all  $\mathcal{S}_A$ -closed clones by applying Theorem 3.1 and the subsequent discussion on the lattice of  $G$ -closed clones to the case  $G = \mathcal{S}_A$ . It follows from Corollary 2.7 that the two disjoint intervals of clones of type (U) are 3- or 4-element chains corresponding to the chain of normal subgroups of  $\mathcal{S}_A$ . For  $|A| \geq 5$  the group  $\mathcal{S}_A$  is not an affine general linear group, therefore there exist no  $\mathcal{S}_A$ -closed clones of type (A) or (Q). For  $|A| = 4$  we have  $\mathcal{S}_A = \text{AGL}(2, 2)$ , and up to the choice of 0, there is a unique 2-group  $\underline{A}$  such that  $\mathcal{S}_A = \text{AGL}(\underline{A})$ . In this case the intervals in (3.1) are 3-element chains. Therefore there are nine  $\mathcal{S}_A$ -closed clones of type (A) and one of type (Q). For  $|A| = 3$  we have  $\mathcal{S}_A = \text{AGL}(1, 3)$ , and up to the choice of 0, there is a unique group  $\underline{A}$  such that  $\mathcal{S}_A = \text{AGL}(\underline{A})$ . In this case each interval in (3.1) is a singleton. Therefore there are three  $\mathcal{S}_A$ -closed clones of type (A) and one of type (Q). In either case, the following two classes of  $\mathcal{S}_A$ -closed clones  $\mathfrak{C}$  remain to be described:

- (S)  $\mathfrak{C}$  is the clone of a simple algebra  $\langle A; \mathfrak{C} \rangle$  such that  $\mathfrak{C}$  is contained in the Slupecki clone, and contains at least one transformation that is neither constant nor a permutation; and
- (I)  $\mathfrak{C}$  is an idempotent clone such that  $\langle A; \mathfrak{C} \rangle$  is a simple algebra, but not affine.

**Theorem 4.1.** [14] *Let  $A$  be a finite set with  $|A| \geq 3$ . The  $\mathcal{S}_A$ -closed clones  $\mathfrak{C}$  on  $A$  that satisfy condition (S) are the following:*

- (1)  $[T]$  where  $T$  is an  $\mathcal{S}_A$ -closed transformation monoid on  $A$  (see Corollary 2.7) such that  $\mathcal{C}_A \subseteq T \not\subseteq \mathcal{S}_A \cup \mathcal{C}_A$ ;
- (2)  $\mathfrak{B} \cup [T]$  where  $T$  is as in (1);
- (2)\*  $\mathfrak{B}^* \cup [T]$  if  $|A|$  is even, where  $T$  is as in (1) and the kernel type of each nonsurjective member of  $T$  consists of even numbers;

(3)  $\mathfrak{R}_m \cup [T]$  where  $2 \leq m < |A|$  and  $T$  is as in (1).

The representation of each  $\mathcal{S}_A$ -closed clone of type (S) described in Theorem 4.1 will be unique if we require  $T$  to be the unary part of the clone, or equivalently, if we require

- in case (2) that  $T$  contains all transformations with range of size at most 2;
- in case (2)\* that  $T$  contains all transformations with range of size at most 2 and with kernel type consisting of even numbers; and
- in case (3) that  $T$  contains all transformations with range of size at most  $m$ .

It is easy to see that for two  $\mathcal{S}_A$ -closed clones of type (S) which are given in this unique form as  $\mathfrak{X} \cup [T]$  and  $\mathfrak{X}' \cup [T']$  ( $\mathfrak{X} = \emptyset, \mathfrak{B}, \mathfrak{B}^*$ , or  $\mathfrak{R}_m$ ) we have  $\mathfrak{X} \cup [T] \subseteq \mathfrak{X}' \cup [T']$  if and only if  $\mathfrak{X} \subseteq \mathfrak{X}'$  and  $T \subseteq T'$ .

*Sketch of proof of Theorem 4.1.* ([20]) It is easy to see that all clones listed in the theorem are  $\mathcal{S}_A$ -closed and satisfy condition (S). Conversely, let  $\mathfrak{C}$  be an  $\mathcal{S}_A$ -closed clone satisfying condition (S), and let  $\mathbf{A} = \langle A; \mathfrak{C} \rangle$ . Since  $\mathfrak{C}$  is  $\mathcal{S}_A$ -closed, so is the transformation monoid  $T = \mathfrak{C}^{(1)}$ . Therefore Corollary 2.7 applies, and shows in particular that  $T$  contains all constants. Hence  $\mathfrak{C} = \text{Pol}(\mathbf{A})$  and  $T = \text{Pol}_1(\mathbf{A})$ . If  $\mathfrak{C}$  is an essentially unary clone, then there is nothing more to prove to see that (1) holds.

From now on we will assume that  $\mathfrak{C}$  is not essentially unary. Let  $r$  denote the maximum of the cardinalities of ranges of operations  $p \in \mathfrak{C}$  that depend on more than one variable. Since  $\mathfrak{C}$  is contained in the Slupecki clone and has an operation that depends on more than one variable we have  $2 \leq r < |A|$ . We know from condition (S) that  $\mathbf{A}$  is simple. Corollary 2.7 implies that for some positive integers  $k_1$  and  $k_2$ ,  $T = \text{Pol}_1(\mathbf{A})$  contains all transformations of kernel type  $(k_1, k_2)$ . Thus the minimal idempotent polynomials of  $\mathbf{A}$  have 2-element ranges, and every 2-element subset of  $\mathbf{A}$  is a trace. Remark 3.5 implies that  $\mathbf{A}$  is of type **1**, **2**, or **3**.

Now let us fix a trace  $N$  of  $\mathbf{A}$ , and following [19] let us call a set of the form  $M = f(N, N, \dots, N)$  with  $f \in \text{Pol}(\mathbf{A}) = \mathfrak{C}$  a *multitrace* of  $\mathbf{A}$ . Furthermore, let  $m$  denote the size of the largest multitrace in  $\mathbf{A}$ . It is easy to see that  $m \leq r$ . Indeed, if  $m = 2$  then this is clear since  $r \geq 2$ . If  $m > 2$  and  $M = f(N, N, \dots, N)$  is a multitrace with  $|M| = m$ , then  $f$  must depend on more than one variable, so  $m = |f(N, N, \dots, N)| \leq |f(A, A, \dots, A)| \leq r$ .

We will now show that  $m = r$  and every  $r$ -element subset of  $\mathbf{A}$  is a multitrace. First we argue that every  $m$ -element subset of  $\mathbf{A}$  is a multitrace. Let  $M = f(N, \dots, N)$  ( $f \in \mathfrak{C}$ ) be a multitrace of  $\mathbf{A}$  such that  $m = |M|$ , and let  $\pi \in \mathcal{S}_A$ . Then  ${}^\pi M = {}^\pi f({}^\pi N, \dots, {}^\pi N)$ . Since  ${}^\pi N$  has size 2 it is a trace, so there is a polynomial isomorphism  $g: N \rightarrow {}^\pi N$ . The polynomial  $f'(x_1, \dots, x_n) = {}^\pi f(g(x_1), \dots, g(x_n))$  witnesses the fact that  ${}^\pi M = f'(N, \dots, N)$  is a multitrace. This shows how to express any subset of size  $m$  as a multitrace. It remains to prove that  $m \not\leq r$ . Our argument is based on Yablonskiĭ's Lemma:

**Lemma 4.2.** [42] *Let  $A$  be a finite set and let  $f(x_1, \dots, x_n)$  be an operation on  $A$  that depends on more than one variable. If  $|f(A, A, \dots, A)| > m$  for some  $m > 1$ , then there exist  $m$ -element subsets  $M_1, \dots, M_n \subseteq A$  for which  $|f(M_1, M_2, \dots, M_n)| > m$ .*

If  $m < r$ , then  $\mathbf{A}$  has a polynomial  $f$  such that  $f$  depends on more than one variable, and  $|f(A, \dots, A)| = r > m$ . By Lemma 4.2 there are  $m$ -element subsets  $M_1, \dots, M_n$  such that  $|f(M_1, M_2, \dots, M_n)| > m$ . But all  $m$ -element subsets are multitraces, so each  $M_i$  equals  $f_i(N, \dots, N)$  for some  $f_i \in \mathfrak{C}$ . Hence

$$f(M_1, M_2, \dots, M_n) = f(f_1(N, \dots, N), \dots, f_n(N, \dots, N))$$

is a multitrace of size larger than  $m$ , which is impossible. This proves our claim that  $m = r$  and every  $r$ -element subset of  $\mathbf{A}$  is a multitrace.

Now we are in a position to use the structure theorem for multitraces of types **1**, **2**, and **3**.

**Theorem 4.3.** [19] *If  $N$  is a trace of the simple algebra  $\mathbf{A}$  of type **1, 2**, or **3**, and  $M = f(N, \dots, N)$  is a multitrace, then*

- (1)  $M = e(A)$  for some idempotent unary polynomial  $e \in \text{Pol}_1(\mathbf{A})$ , and
- (2) the induced algebra  $\mathbf{A}|_M$  is term equivalent to
  - (i) a matrix power  $(\mathbf{A}|_N)^{[k]}$  if  $\mathbf{A}$  is of type **1** or **2**;
  - (ii) a primal algebra if  $\mathbf{A}$  is of type **3**.

Suppose first that  $\mathbf{A}$  is of type **1** or **2**. By Theorem 4.3 the size of every multitrace of  $\mathbf{A}$  is a power of  $|N| = 2$ . On the other hand, it is easy to see that if  $M = f(N, \dots, N)$  is a multitrace of  $\mathbf{A}$ , then so is every subset  $M'$  of  $M$ . Indeed, Corollary 2.7 and part (1) of Theorem 4.3 yield that  $T = \text{Pol}_1(\mathbf{A})$  contains a unary polynomial  $h$  with  $h(M) = M'$ , and hence  $M' = hf(N, \dots, N)$  is a multitrace. Thus  $\mathbf{A}$  cannot have a multitrace of size  $> 2$ . Hence  $m = 2$ . This means that every operation  $f \in \mathfrak{C}$  that depends on more than one variable has 2-element range, and hence the range is a trace. If  $\mathbf{A}$  is of type **1**, then such an  $f$  cannot exist by [17], Theorem 5.6, Claim 3.

Hence  $\mathbf{A}$  is of type **2**. The arguments in the preceding paragraph imply that  $\mathfrak{C} = (\mathfrak{C} \cap \mathfrak{R}_2) \cup [T]$ . We will prove that  $\mathfrak{C} \cap \mathfrak{R}_2$  equals  $\mathfrak{B}$  or  $\mathfrak{B}^*$ , and hence  $\mathfrak{C}$  is one of the clones described in (2) or (2)\*. Let  $N = \{0, 1\}$ , and let  $x + y$  denote a polynomial of  $\mathbf{A}$  whose restriction to  $N$  is the vector space addition on  $N$ . Since traces are polynomially isomorphic, every operation  $f' \in \mathfrak{C} \cap \mathfrak{R}_2$  with range in a trace  $N'$  has the form  $pf$  for an operation  $f \in \mathfrak{C} \cap \mathfrak{R}_2$  with range in  $N$  and a polynomial isomorphism  $p: N \rightarrow N'$ ,  $p \in T$ . Furthermore, in the fourth paragraph of the proof of Theorem 13.5 of [17] it is shown that any polynomial operation of a type **2** simple algebra  $\mathbf{A}$  that has range in a trace  $N$  is constructible from unary polynomials of  $\mathbf{A}$  and from  $x + y$ ; in fact, any polynomial is a sum of unary polynomials. Therefore we have to determine the unary operations in  $\mathfrak{C} \cap \mathfrak{R}_2$  whose range is contained in  $N$ .

A unary operation  $f: A \rightarrow N = \{0, 1\}$  from  $\mathfrak{C} \cap \mathfrak{R}_2$  can be thought of as a characteristic function on  $A$  which may be identified with its support  $U_f = \{a \in A :$

$f(a) = 1\}$ . The family  $\mathbf{S}$  of subsets of  $\mathbf{A}$  that are supports of unary operations  $f: A \rightarrow N = \{0, 1\}$  from  $\mathfrak{C} \cap \mathfrak{R}_2$  has the following properties:

- (i)  $\mathbf{S}$  contains  $\emptyset$ ,  $A$ , and at least one nonempty proper subset of  $A$ .
- (ii)  $\mathbf{S}$  is closed under symmetric difference,  $\oplus$ .
- (iii) If  $U$  is in  $\mathbf{S}$ , then every subset  $V \subseteq A$  with  $|V| = |U|$  is also in  $\mathbf{S}$ .

To verify these properties one can use the following facts: the constant polynomials into  $N$  and a minimal idempotent polynomial  $e$  with  $e(A) = N$  belong to  $\mathfrak{C}$ ; the support of  $f + g$  is  $U_f \oplus U_g$ ; and  $\mathfrak{C}$  is  $\mathcal{S}_A$ -closed.

It follows easily from these properties that  $\mathbf{S}$  contains a set of size 2; moreover,

- if  $\mathbf{S}$  contains a 1-element set, then  $\mathbf{S}$  is the set of all subsets of  $A$ , while
- if  $\mathbf{S}$  contains a 2-element set but no 1-element set, then  $|A|$  is even and  $\mathbf{S}$  is the set of all subsets of  $A$  of even cardinality.

Thus, in the first case,  $\mathfrak{C} \cap \mathfrak{R}_2$  contains every unary operation  $f: A \rightarrow N$ , and the description of  $\mathfrak{C}$  given above yields that  $\mathfrak{C} \cap \mathfrak{R}_2 = \mathfrak{B}$ , and hence  $\mathfrak{C}$  is one of the clones in (2). In the second case, a unary operation  $f: A \rightarrow N$  belongs to  $\mathfrak{C} \cap \mathfrak{R}_2$  if and only if  $f$  has kernel type  $(k_1, k_2)$  where both  $k_1$  and  $k_2$  are even, whence we get that  $\mathfrak{C} \cap \mathfrak{R}_2 = \mathfrak{B}^*$ . It follows also from Theorem 2.6 that the kernel type of each nonsurjective member of  $\mathfrak{C}^{(1)}$  consists of even numbers, therefore  $\mathfrak{C}$  is one of the clones in (2)\*.

Finally, we prove that if  $\mathbf{A}$  is of type  $\mathfrak{3}$ , then  $\mathfrak{C}$  is as described in (3). We established earlier that every operation from  $\mathfrak{C}$  that depends on more than one variable has range in a multitrace of size  $m$ . Thus  $\mathfrak{C} \subseteq \mathfrak{R}_m \cup [T]$ . What remains to show is that  $\mathfrak{R}_m \subseteq \mathfrak{C}$ , which is the assertion that any operation  $f: A^n \rightarrow A$  whose range is of size at most  $m$  is in  $\mathfrak{C}$ . Let  $M$  be a multitrace of  $\mathbf{A}$  of size  $m$  such that  $M$  contains the range of  $f$ , and let  $N' \subseteq M$  be a trace of  $\mathbf{A}$ . Choose polynomials  $p_1, \dots, p_k \in \text{Pol}_1(\mathbf{A})$  with range in  $N'$  which separate the points of  $\mathbf{A}$ . (The existence of these polynomials is guaranteed by Theorem 2.8(4) of [17].) View  $\bar{p} = (p_1, \dots, p_k): A \rightarrow M^k$  as a polynomial injection of  $A$  into  $M^k$ . Since  $f: A^n \rightarrow M$ , we can try to find  $h \in \text{Pol}_{kn}(\mathbf{A}|_M)$  that allows us to factor  $f$  as

$$A^n \xrightarrow{\bar{p}^n} (M^k)^n \xrightarrow{h} M.$$

The existence of such a factorization depends on the ability to interpolate the partial operation  $f \cdot (\bar{p}^n)^{-1}: (M^k)^n \rightarrow M$  by a total operation  $h: (M^k)^n \rightarrow M$  that is a polynomial of  $\mathbf{A}|_M$ . We can do this since  $\mathbf{A}|_M$  is primal (see Theorem 4.3). Thus,  $f$  agrees with some polynomial operation of  $\mathbf{A}$  of the form  $h \cdot \bar{p}^n$ . This concludes the proof of Theorem 4.1.  $\square$

Now we turn to the description of  $\mathcal{S}_A$ -closed clones  $\mathfrak{C}$  that satisfy condition (I). These clones are most conveniently described by data that involve compatible relations as well as information on how the operations from  $\mathfrak{C}$  restrict to certain subalgebras. Accordingly, the proof that is outlined here uses arguments with operations as

well as arguments with relations. This combination of methods seems more effective than restricting to a purely operational or purely relational approach.

We will call a binary relation on  $A$  a *cross* if it has the form

$$\kappa[b, B; c, C] = (\{b\} \times C) \cup (B \times \{c\}) \quad (b \in B, c \in C)$$

for some  $B, C \subseteq A$  with  $|B|, |C| \geq 2$ . An  $r \times s$  *cross* is a cross  $\kappa[b, B; c, C]$  such that  $|B| = r$  and  $|C| = s$ .

For an algebra  $\mathbf{A}$ ,  $\text{Iso}(\mathbf{A})$  will denote the family of all internal isomorphisms of  $\mathbf{A}$  (see Example 2.10 for the definition). It is easy to see that a subset  $B$  of  $A$  is a subalgebra of  $\mathbf{A}$  if and only if  $\text{id}_B \in \text{Iso}(\mathbf{A})$ . For convenience we will allow the empty bijection  $\text{id}_\emptyset$  as an internal isomorphism, and hence the empty set  $\emptyset$  as a subalgebra of  $\mathbf{A}$ . We will say that  $\text{Iso}(\mathbf{A})$  is *m-complete* if all bijections between subsets of  $\mathbf{A}$  of size  $\leq m$  are internal isomorphisms of  $\mathbf{A}$  (in particular, all subsets of  $\mathbf{A}$  of size  $\leq m$  are subalgebras of  $\mathbf{A}$ ). Clearly,  $\text{Iso}(\mathbf{A})$  is 0-complete for every algebra  $\mathbf{A}$ , and  $\text{Iso}(\mathbf{A})$  is 1-complete if and only if  $\mathbf{A}$  is idempotent.

Now let  $\mathfrak{C}$  be an idempotent  $\mathcal{S}_A$ -closed clone on a finite set  $A$  ( $|A| \geq 3$ ), and let  $\mathbf{A} = \langle A; \mathfrak{C} \rangle$ . It is easy to see that in this case

- (4.4)  $\mathbb{I} = \text{Iso}(\mathbf{A})$  is a family of bijections between subsets of  $A$  (considered as binary relations) such that
- (0)  $\mathbb{I}$  contains  $\text{id}_\emptyset, \text{id}_A$ , and all bijections between 1-element subsets of  $A$ ,
  - (1)  $\mathbb{I}$  is closed under intersection,
  - (2)  $\mathbb{I}$  is closed under multiplication and inversion, and
  - (3)  $\mathbb{I}$  is closed under conjugation by permutations from  $\mathcal{S}_A$ .

Applying properties (1) and (3) to  $\text{id}_B \in \mathbb{I}$  ( $B \subseteq A$ ) one can see that

- (4.5) if  $\mathbf{A}$  has a proper subalgebra  $\mathbf{B}$  of size  $|B| = k$ , then every subset of  $A$  of size  $\leq k$  supports a subalgebra of  $\mathbf{A}$ .

Moreover,

- (4.6) if  $\mathbf{B}, \mathbf{C}$  are  $k$ -element subalgebras of  $\mathbf{A}$ , then conjugation by any permutation  $\gamma \in \mathcal{S}_A$  such that  $\gamma(B) = C$  yields an isomorphism  $\text{Clo}(\mathbf{B}) \rightarrow \text{Clo}(\mathbf{C})$ ; in particular, it follows that  $\text{Clo}(\mathbf{B})$  is  $\mathcal{S}_B$ -closed.

We will use the following two parameters associated to  $\mathbf{A}$ :  $\text{sub}_{\mathbf{A}}$  is the maximum size of a proper subalgebra of  $\mathbf{A}$ ;  $\text{cro}_{\mathbf{A}}$  is the largest number  $r$  such that  $\mathbf{A}$  has a compatible  $r \times 2$  cross, if  $\mathbf{A}$  has such a compatible cross, and  $\text{cro}_{\mathbf{A}} = 1$  otherwise. Clearly, we have  $1 \leq \text{sub}_{\mathbf{A}} < |A|$ . It is also easy to see that  $\text{cro}_{\mathbf{A}} = |A|$  or  $\text{cro}_{\mathbf{A}} \leq \text{sub}_{\mathbf{A}}$ . The next theorem shows that if  $\mathfrak{C} = \text{Clo}(\mathbf{A})$  satisfies condition (I), then it is determined by the following data: the internal isomorphisms of  $\mathbf{A}$ , the parameter  $\text{cro}_{\mathbf{A}}$ , and the clone of a 2-element subalgebra of  $\mathbf{A}$  (if any). In particular, it follows that there are only finitely many  $\mathcal{S}_A$ -closed clones that satisfy condition (I).

**Theorem 4.7.** [20] (cf. [15, 28]) *Let  $A$  be a finite set with  $|A| \geq 3$ , and let  $\mathbf{A} = \langle A; \mathfrak{C} \rangle$  where  $\mathfrak{C}$  is an  $\mathcal{S}_A$ -closed clone on  $A$  that satisfies condition (I). Then one of the following conditions holds for  $\mathbf{A}$ :*

- (Q)  $\mathbf{A}$  is quasiprimal;
- (P)  $\text{sub}_{\mathbf{A}} \geq 2$ , the 2-element subalgebras of  $\mathbf{A}$  are term equivalent to 2-element affine spaces, and an operation  $f$  is a term operation of  $\mathbf{A}$  if and only if  $f$  preserves the internal isomorphisms of  $\mathbf{A}$  and  $f|_B \in \text{Clo}(\mathbf{B})$  for all 2-element subalgebras  $\mathbf{B}$  of  $\mathbf{A}$ ;
- (D)  $r = \text{cro}_{\mathbf{A}} \geq 2$ ,  $\text{Iso}(\mathbf{A})$  is 2-complete if  $r > 2$ , and an operation  $f$  is a term operation of  $\mathbf{A}$  if and only if  $f$  preserves the internal isomorphisms of  $\mathbf{A}$  and
  - all  $r \times 2$  crosses if  $r > 2$ ,
  - all reflexive  $2 \times 2$  crosses if  $r = 2$ .
- (E)  $r = \text{cro}_{\mathbf{A}} \geq 2$ ,  $\text{Iso}(\mathbf{A})$  is  $r$ -complete if  $r > 2$ , and an operation  $f$  is a term operation of  $\mathbf{A}$  if and only if  $f$  preserves the internal isomorphisms of  $\mathbf{A}$  and  $f|_B$  is a projection for all  $r$ -element subalgebras  $\mathbf{B}$  of  $\mathbf{A}$ .

This classification shows, in particular, that if  $\mathbf{A}$  satisfies the assumptions of Theorem 4.7, then  $\mathbf{A}$  has the dual discriminator (see Example 2.9) as a term operation if and only if  $\mathbf{A}$  is of type (Q) or (D), and  $\mathbf{A}$  is paraprimial (see [5]) if and only if  $\mathbf{A}$  is of type (Q) or (P).

Before outlining the proof of Theorem 4.7 we will show how this theorem can be transformed into an explicit description of all  $\mathcal{S}_A$ -closed clones satisfying condition (I). First we have to determine all possible sets  $\text{Iso}(\mathbf{A})$  of internal isomorphisms, and then list for each such set  $\mathbb{I}$  all  $\mathcal{S}_A$ -closed clones  $\mathfrak{C}$  that satisfy conditions (I) and  $\mathbb{I} = \text{Iso}(\langle A; \mathfrak{C} \rangle)$ .

The next lemma explicitly describes all families  $\mathbb{I}$  of bijections that satisfy conditions (4.4)(0)–(3) above. The description uses the following notation.  $\text{Bij}_m(A)$  denotes the collection of all bijections between  $m$ -element subsets of  $A$  ( $0 \leq m < |A|$ ). For even  $|A|$ ,  $\text{Bij}_{|A|/2}^\circ(A)$  denotes the set of all bijections  $B \rightarrow C$  between  $|A|/2$ -element subsets  $B, C$  of  $A$  such that either  $B = C$  or  $B, C$  are complements of each other. Finally, for a nontrivial normal subgroup  $N$  of  $\mathcal{S}_A$ ,  $\text{Restr}_m(N)$  denotes the set of bijections between  $m$ -element subsets of  $A$  that are restrictions of members of  $N$ . Clearly,  $\text{Restr}_2(\mathcal{V}_A) = \text{Bij}_2^\circ(A)$  if  $|A| = 4$ ,  $\text{Restr}_m(\mathcal{A}_A) = \text{Bij}_m(A)$  if  $1 \leq m \leq |A| - 2$ , and  $\text{Restr}_m(\mathcal{S}_A) = \text{Bij}_m(A)$  if  $1 \leq m \leq |A| - 1$ .

**Lemma 4.8.** *Let  $A$  be a finite set with  $|A| \geq 3$  and let  $\mathbb{I}$  be a family of bijections between subsets of  $A$  such that  $\mathbb{I}$  satisfies conditions (4.4)(0)–(3). Then  $\mathbb{I}$  is one of the following families:*

- (i)  $\mathbb{J}_{k,l} = \bigcup (\text{Bij}_s(A) : 0 \leq s \leq k) \cup \{\text{id}_B : B \subseteq A, |B| \leq l\} \cup \{\text{id}_A\}$  for some integers  $k, l$  with  $1 \leq k \leq l < |A|$ ;
- (ii) (a)  $\mathbb{J}_{3,l} \cup \bigcup (\mathcal{V}_B : B \subseteq A, |B| = 4)$  for some  $l$  with  $3 < l < |A|$ ,
- (b)  $\mathbb{J}_{k,l} \cup \bigcup (\mathcal{A}_B : B \subseteq A, |B| = k + 1)$  for some  $k, l$  with  $2 \leq k < l < |A|$ ,

- (c)  $\mathbb{J}_{k,l} \cup \bigcup (\mathcal{S}_B : B \subseteq A, |B| = k+1)$  for some  $k, l$  with  $1 \leq k < l < |A|$ ;
- (iii)  $\mathbb{J}_{|A|/2-1,l} \cup \text{Bij}_{|A|/2}^\circ(A)$  for some  $l$  with  $|A|/2 \leq l < |A|$ , if  $|A|$  is even;
- (iv) (a)  $\mathbb{J}_{|A|-2,|A|-1} \cup \text{Restr}_{|A|-1}(\mathcal{A}_A)$ ,  
 (b)  $\mathbb{J}_{2,3} \cup \text{Restr}_3(\mathcal{V}_A)$ , if  $|A| = 4$ ,  
 (c)  $\mathbb{J}_{1,3} \cup \text{Bij}_2^\circ(A) \cup \text{Restr}_3(\mathcal{V}_A)$ , if  $|A| = 4$ ;
- (v) (a)  $\mathbb{J}_{k,k} \cup N$  for some  $k \geq 1$  with  $|A| - 3 \leq k < |A|$  and for some nontrivial normal subgroup  $N$  of  $\mathcal{S}_A$  such that  $k \geq |A| - 2$  if  $N = \mathcal{S}_A$ ,  
 (b)  $\mathbb{J}_{|A|-2,|A|-1} \cup \text{Restr}_{|A|-1}(\mathcal{A}_A) \cup N$  for a nontrivial normal subgroup  $N$  of  $\mathcal{S}_A$  with  $N \subseteq \mathcal{A}_A$ ,  
 (c)  $\mathbb{J}_{2,3} \cup \text{Restr}_3(\mathcal{V}_A) \cup \mathcal{V}_A$ , if  $|A| = 4$ ,  
 (d)  $\mathbb{J}_{1,3} \cup \text{Bij}_2^\circ(A) \cup \text{Restr}_3(\mathcal{V}_A) \cup \mathcal{V}_A$ , if  $|A| = 4$ ,  
 (e)  $\mathbb{J}_{1,2} \cup \text{Bij}_2^\circ(A) \cup \mathcal{V}_A$ , if  $|A| = 4$ .

These families of bijections between subsets of  $A$  are naturally ordered by inclusion, and form a lattice. Figures 3–5 show these lattices for  $|A| \geq 5$ ,  $|A| = 4$ , and  $|A| = 3$ , respectively. In the diagrams the triangular array of large bullets represents the families  $\mathbb{J}_{k,l}$  ( $1 \leq k \leq l < |A|$ ) from (i); in particular, the top bullet corresponds to  $\mathbb{J}_{|A|-1,|A|-1}$ , the bottom rightmost bullet to  $\mathbb{J}_{1,1}$ , and the bottom leftmost bullet (at the right angle of the triangle) to  $\mathbb{J}_{1,|A|-1}$ . The small bullets and the circles represent the families listed in (ii) and (iii), respectively (type (iii) exists only if  $|A|$  is even); for each pair  $k, l$  with  $k < l$  these form a chain between  $\mathbb{J}_{k,l}$  and  $\mathbb{J}_{k+1,l}$ . The families in (iv) are denoted by diamonds in Figures 3–5. Finally, the families in (v), which are distinguished from those in (i)–(iv) by the property that they contain nonidentity permutations from  $\mathcal{S}_A$ , are denoted in Figures 3–5 by squares.

The main ingredient of the proof of Lemma 4.8 is to show that if  $I$  is a family of bijections between  $m$ -element subsets of  $A$  for a fixed integer  $1 < m < |A|$  such that  $I$  satisfies conditions (4.4)(2)–(3) and  $I$  contains a bijection between two distinct  $m$ -element subsets of  $A$ , then the following holds for  $I$ :

- If  $m < |A| - 1$  then either  $I = \text{Bij}_m(A)$ , or  $|A|$  is even,  $m = |A|/2$ , and  $I = \text{Bij}_{|A|/2}^\circ(A)$ . In both cases  $\mathcal{S}_B \subseteq I$  for all  $m$ -element subsets  $B$  of  $A$ .
- If  $m = |A| - 1$ , then there exists a nontrivial normal subgroup  $N$  in  $\mathcal{S}_A$  such that  $I = \text{Restr}_{|A|-1}(N)$ .

The next theorem will show that for every family  $\mathbb{I}$  of bijections from Lemma 4.8 there exists an  $\mathcal{S}_A$ -closed clone  $\mathfrak{C}$  that satisfies conditions (I) and  $\mathbb{I} = \text{Iso}(\langle A; \mathfrak{C} \rangle)$ . An explicit list of all such clones is also given in the theorem. We will use the following notation. If  $\mathbb{I} = \mathbb{J}_{k,l} \cup \dots$  is one of the families listed in Lemma 4.8, then we define  $\mathfrak{Q}(\mathbb{I})$  to be the set of all operations on  $A$  that preserve all members of  $\mathbb{I}$  (as binary relations). Clearly,  $\mathfrak{Q}(\mathbb{I})$  is the clone of an idempotent quasiprimal algebra.

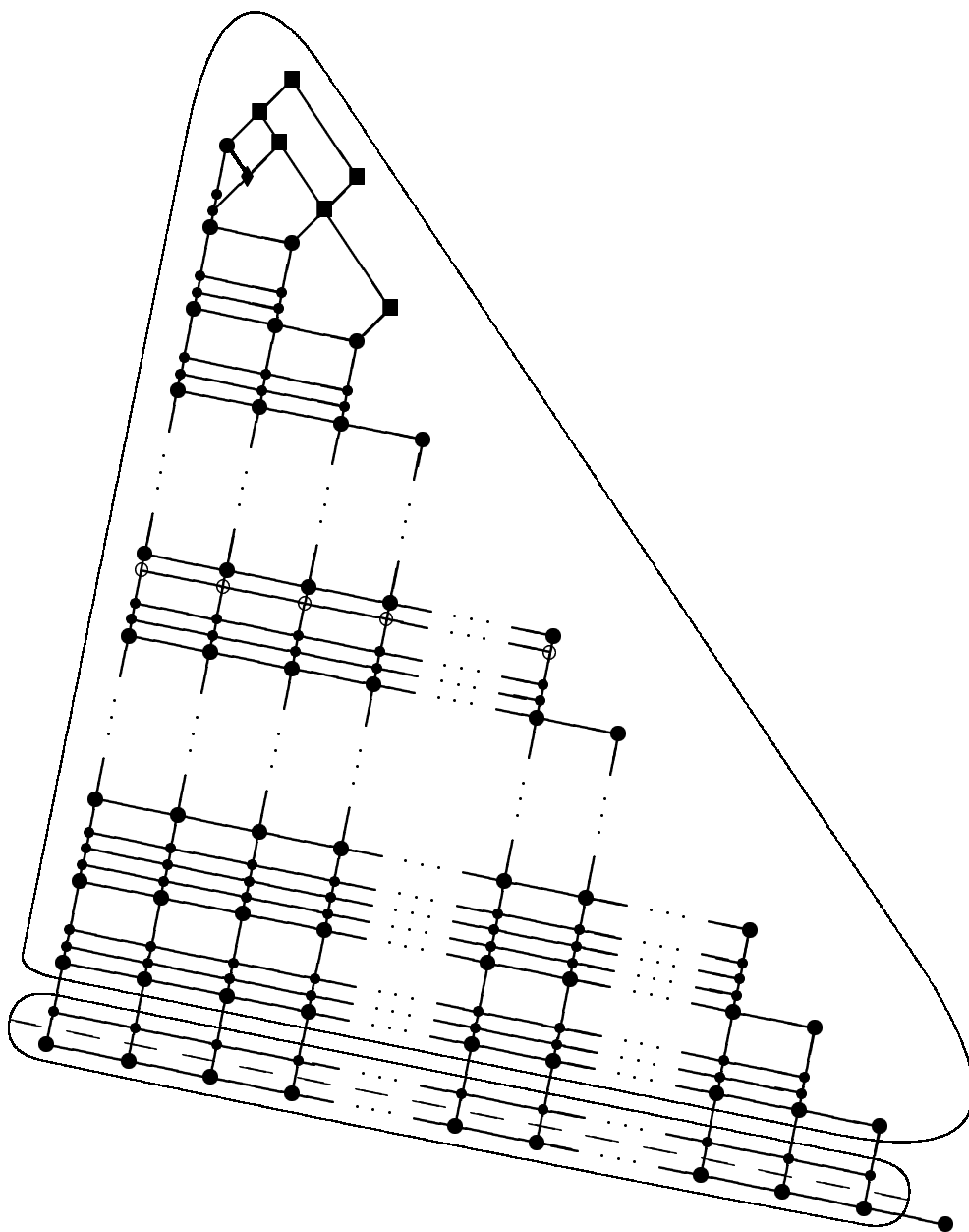

FIGURE 3. Lattice of possible families of internal isomorphisms,  $|A| \geq 5$

Furthermore, let

$$\begin{aligned}
 \mathfrak{D}_2(\mathbb{I}) &= \{f \in \mathfrak{Q}(\mathbb{I}) : f|_B \in \text{Clo}(\langle B; \wedge, \vee \rangle) \text{ for all 2-element subsets } B \text{ of } A\} \\
 &= \{f \in \mathfrak{Q}(\mathbb{I}) : f \text{ preserves all reflexive crosses on 2-element subsets of } A\}, \\
 \mathfrak{D}_r(\mathbb{I}) &= \{f \in \mathfrak{Q}(\mathbb{I}) : f \text{ preserves all } r \times 2 \text{ crosses}\} \quad (3 \leq r \leq |A|), \\
 \mathfrak{P}(\mathbb{I}) &= \{f \in \mathfrak{Q}(\mathbb{I}) : f|_B \in \text{Clo}(\langle B; x + y + z \rangle) \text{ for all 2-element subsets } B \text{ of } A\}, \\
 \mathfrak{E}_r(\mathbb{I}) &= \{f \in \mathfrak{Q}(\mathbb{I}) : f|_B \text{ is a projection for all } r\text{-element subsets } B \text{ of } A\} \\
 &\quad (2 \leq r \leq |A|).
 \end{aligned}$$



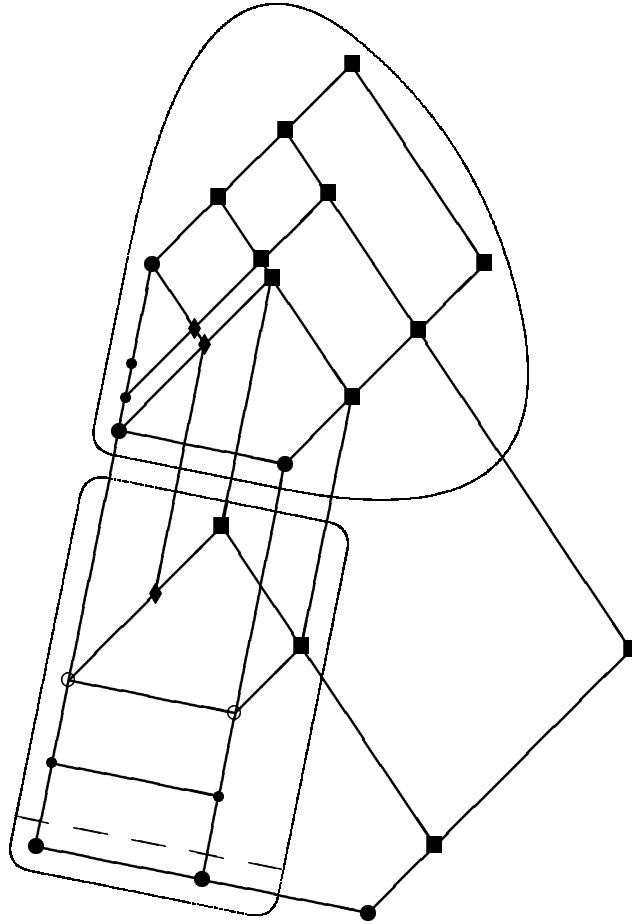

FIGURE 4. Lattice of possible families of internal isomorphisms,  $|A| = 4$

The two descriptions of  $\mathfrak{D}_2(\mathbb{I})$  are equivalent, because a reflexive  $2 \times 2$  cross is a partial order on a 2-element subset of  $A$ . Note that if  $k \geq 2$ , then there is a third description as well, namely

$$\mathfrak{D}_2(\mathbb{I}) = \{f \in \mathfrak{Q}(\mathbb{I}) : f \text{ preserves all } 2 \times 2 \text{ crosses}\},$$

because every  $2 \times 2$  cross is a relational product of a reflexive  $2 \times 2$  cross and a bijection from  $\text{Bij}_2(A) \subseteq \mathbb{I}$ . This means that in the case when  $k \geq 2$ ,  $\mathfrak{D}_2(\mathbb{I})$  can be defined by a condition analogous to the condition defining  $\mathfrak{D}_r(\mathbb{I})$  for  $r \geq 3$ .

**Theorem 4.9.** [15, 28, 20] *Let  $A$  be a finite set with  $|A| \geq 3$ , and let  $\mathbb{I} = \mathbb{J}_{k,l} \cup \dots$  be a family of bijections from Lemma 4.8. The  $\mathcal{S}_A$ -closed clones  $\mathfrak{C}$  that satisfy condition (I) and have the property that  $\mathbb{I} = \text{Iso}(\langle A; \mathfrak{C} \rangle)$  are the following.*

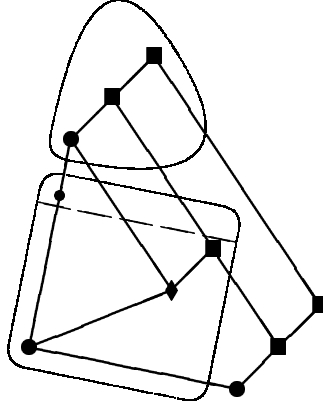

FIGURE 5. Lattice of possible families of internal isomorphisms,  $|A| = 3$

- (1) If  $k \geq 2$ , then there are exactly  $k + l + 1$  such clones  $\mathfrak{C}$ , namely  $\mathfrak{Q}(\mathbb{I})$ ,  $\mathfrak{D}_r(\mathbb{I})$  ( $r = 2, \dots, l$  or  $r = |A|$ ),  $\mathfrak{P}(\mathbb{I})$ , and  $\mathfrak{E}_s(\mathbb{I})$  ( $s = 2, \dots, k$ ).
- (2) If  $l > k = 1$ , and  $\mathcal{S}_B \subseteq \mathbb{I}$  for all 2-element subsets  $B$  of  $A$ , then  $\mathfrak{C}$  is one of the four clones  $\mathfrak{Q}(\mathbb{I})$ ,  $\mathfrak{D}_2(\mathbb{I})$ ,  $\mathfrak{P}(\mathbb{I})$ , or  $\mathfrak{E}_2(\mathbb{I})$ .
- (3) If  $l > k = 1$ , and  $\mathbb{I} \cap \mathcal{S}_B = \{\text{id}_B\}$  for all 2-element subsets  $B$  of  $A$ , then  $\mathfrak{C}$  equals  $\mathfrak{Q}(\mathbb{I})$  or  $\mathfrak{D}_2(\mathbb{I})$ .
- (4) Finally, if  $k = l = 1$ , then  $\mathfrak{C}$  must be the clone  $\mathfrak{Q}(\mathbb{I})$ .

The clones listed above are pairwise distinct.

In Figures 3–5 the four cases for  $\mathbb{I}$  that are distinguished in Theorem 4.9 are indicated as follows. The families  $\mathbb{I}$  with  $k \geq 2$  are those that appear in the triangular region. The families  $\mathbb{I}$  with  $l > k = 1$  are inside the rectangular region, and the two subclasses distinguished by the property “ $\mathcal{S}_B \subseteq \mathbb{I}$  for all 2-element subsets  $B$  of  $A$ ” and by the complementary property “ $\mathbb{I} \cap \mathcal{S}_B = \{\text{id}_B\}$  for all 2-element subsets  $B$  of  $A$ ” are separated by a dashed line. The remaining families  $\mathbb{I}$  are those with parameters  $k = l = 1$ . Figure 6 shows the clones listed in Theorem 4.9 for four typical families  $\mathbb{I} = \mathbb{I}_j$  ( $j = 1, 2, 3, 4$ ). For each  $j$  the family  $\mathbb{I} = \mathbb{I}_j$  represents the case when  $\mathbb{I}$  satisfies the assumptions of part (j) of Theorem 4.9, and the corresponding clones are ordered by inclusion.

The fact that every  $\mathcal{S}_A$ -closed clone satisfying condition (I) is one of the clones listed in Theorem 4.9 is immediate from Theorem 4.7. What is new in Theorem 4.9 is the statement that the clones  $\mathfrak{X}(\mathbb{I})$  ( $\mathfrak{X} = \mathfrak{Q}, \mathfrak{P}, \mathfrak{D}_r$ , or  $\mathfrak{E}_s$ ) appearing in the theorem are pairwise distinct, and that for every such clone we have  $\mathbb{I} = \text{Iso}(\langle A; \mathfrak{X}(\mathbb{I}) \rangle)$ . Both of these statements can be proved by finding enough operations in the given clones that witness the required properties; for example, the operations in Example 2.9 can be used to show that  $\mathfrak{X}(\mathbb{I}) \neq \mathfrak{X}'(\mathbb{I})$  if  $\mathfrak{X} \neq \mathfrak{X}'$ . In this way we can also prove that for

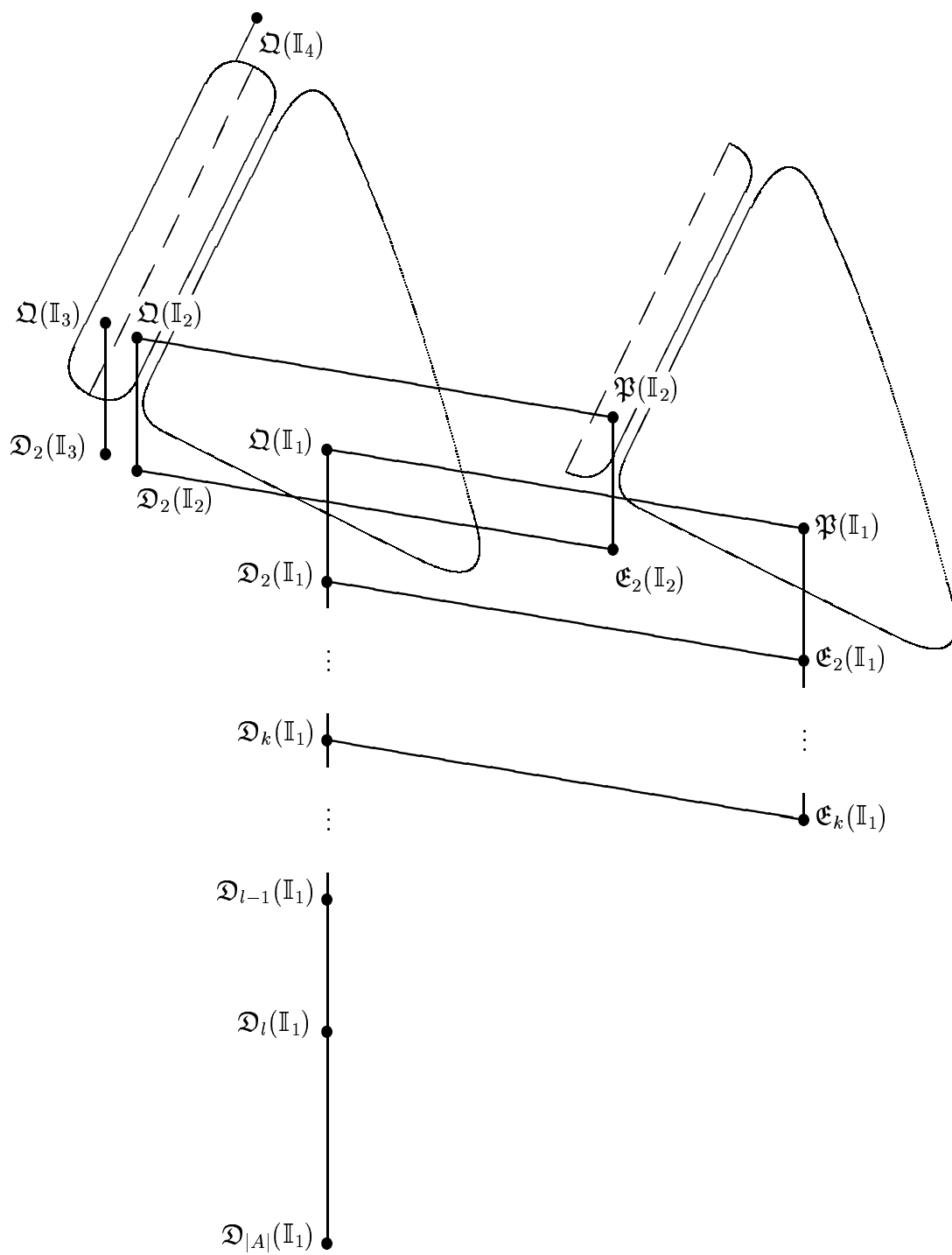

FIGURE 6

two clones  $\mathfrak{X}(\mathbb{I})$  and  $\mathfrak{X}'(\mathbb{I}')$  appearing in the theorem we have  $\mathfrak{X}(\mathbb{I}) \subseteq \mathfrak{X}'(\mathbb{I}')$  if and only if  $\mathbb{I} \supseteq \mathbb{I}'$  — whence  $\mathfrak{X}'(\mathbb{I}) \subseteq \mathfrak{X}'(\mathbb{I}')$  where  $\mathfrak{X}'(\mathbb{I})$ , too, is one of the clones appearing in the theorem — and  $\mathfrak{X}(\mathbb{I}) \subseteq \mathfrak{X}'(\mathbb{I})$  holds by Figure 6.

This completes the description of  $\mathcal{S}_A$ -closed clones. From the discussions at the beginning of Section 4, after Theorem 4.1, and in the preceding paragraph we also know the comparability relation between  $\mathcal{S}_A$ -closed clones that are of the same type (U), (A), (Q), (S), or (I). The comparabilities between  $\mathcal{S}_A$ -closed clones of different types are easy to determine from the descriptions of the clones. Putting all this information together, and using Figure 2 as a ‘skeleton’ one can get a full description of the lattice of  $\mathcal{S}_A$ -closed clones for each finite set  $A$  with  $|A| \geq 3$ .

*Outline of proof of Theorem 4.7.* ([20]) It is well known and easy to check that the collection of all compatible relations of an algebra is closed under the following constructions: intersection, direct product, permutation of coordinates, and projection onto some of the coordinates. If  $\mathbf{A}$  is an idempotent algebra, then the family of compatible relations of  $\mathbf{A}$  is also closed under substituting an element  $a \in A$  into a relation  $\rho = \rho(x_1, \dots, x_n) \subseteq A^n$  to yield an  $(n-1)$ -ary relation

$$\rho(x_1, \dots, x_{i-1}, a, x_i, \dots, x_{n-1}) = \{\langle x_1, \dots, x_{n-1} \rangle : \langle x_1, \dots, x_{i-1}, a, x_i, \dots, x_{n-1} \rangle \in \rho\}.$$

Furthermore, if  $\text{Clo}(\mathbf{A})$  is an  $\mathcal{S}_A$ -closed clone, then the collection of compatible relations of  $\mathbf{A}$  is closed under conjugation by all permutations from  $\mathcal{S}_A$  (cf. Claim 2.3). Therefore, if  $\mathbf{A}$  satisfies the assumptions of Theorem 4.7, then the collection of compatible relations of  $\mathbf{A}$  is closed under all these constructions. We use this fact throughout the proof when we construct new compatible relations from given ones. For a relation  $\rho \subseteq A^n$  and  $I \subseteq \{1, \dots, n\}$ ,  $\text{pr}_I \rho$  will denote the projection of  $\rho$  onto its coordinates in  $I$ . The *size* of  $\rho$  is the number  $\max(|\text{pr}_i \rho| : 1 \leq i \leq n)$ .

We will call a relation *reduced* if no permutation of coordinates transforms it into a direct product of relations of smaller arity, and no projection onto two coordinates is a bijection between two sets. In particular, a binary compatible relation of an algebra is reduced if and only if it is neither a direct product of two subalgebras, nor an internal isomorphism. It follows easily from Claim 2.2 that

**(4.10)** an operation belongs to the clone of  $\mathbf{A}$  if and only if it preserves the internal isomorphisms of  $\mathbf{A}$  and the reduced compatible relations of  $\mathbf{A}$ .

Therefore, to prove Theorem 4.7, we have to understand the reduced compatible relations of the algebras  $\mathbf{A} = \langle A; \mathfrak{C} \rangle$  where  $\mathfrak{C}$  is an  $\mathcal{S}_A$ -closed clone satisfying condition (I). The following theorem helps reduce most of our considerations to binary relations.

**Theorem 4.11.** [39] *Let  $\mathbf{A}$  be a finite idempotent algebra, let  $n \geq 2$ , and let  $\sigma$  be an  $n$ -ary reduced compatible relation of  $\mathbf{A}$ . For  $1 \leq i \leq n$  let  $\mathbf{B}_i$  denote the subalgebra of  $\mathbf{A}$  whose universe is  $\text{pr}_i \sigma$ . Then one of the following conditions holds:*

- (i)  $\mathbf{A}$  has a reduced binary compatible relation  $\rho$  of the same size as  $\sigma$ ;
- (ii)  $\mathbf{B}_1, \dots, \mathbf{B}_n$  are isomorphic simple affine subalgebras of  $\mathbf{A}$ .

Now we outline the main steps of the proof of Theorem 4.7, describing the key ideas for each step. Let  $\mathbf{A} = \langle A; \mathfrak{C} \rangle$  where  $\mathfrak{C}$  is an  $\mathcal{S}_A$ -closed clone on a finite set  $A$  ( $|A| \geq 3$ ) and  $\mathfrak{C}$  satisfies condition (I). Combining property (4.5) with the assumption that  $\mathbf{A}$  is not affine, and then Theorem 4.11 with statements (4.6) and (4.10) we get the following.

- (4.12) If  $\mathbf{B}$  is an affine subalgebra of  $\mathbf{A}$ , then  $|B| \leq 2$ ; hence,  
(4.13) if  $\mathbf{A}$  has no binary reduced compatible relation, then (Q) or (P) holds.

Therefore, from now on, we assume that  $\mathbf{A}$  has a binary reduced compatible relation. Using the existence of such a relation  $\rho$  and the constructions described at the beginning of the proof along with some of the properties of  $\mathbf{A}$  established earlier, one can prove the following preparatory claims on subalgebras, compatible crosses, and internal isomorphisms of  $\mathbf{A}$ .

- (4.14)  $\text{sub}_{\mathbf{A}} \geq 2$ .  
(4.15) If a subalgebra  $\mathbf{B}$  of  $\mathbf{A}$  is not simple, then  $\mathbf{B}$  is a projection algebra.  
(4.16)  $\text{cro}_{\mathbf{A}} \geq 2$ .  
(4.17) If  $\kappa[b, B; c, C]$  with  $B = \{b, b'\}$  and  $C = \{c, c'\}$  is a  $2 \times 2$  compatible cross of  $\mathbf{A}$ , then the bijection  $\iota: B \rightarrow C, b \mapsto c', b' \mapsto c$  belongs to  $\text{Iso}(\mathbf{A})$ .  
(4.18) Every 2-element subset of  $\mathbf{A}$  is a subalgebra, and either every 2-element subalgebra  $\mathbf{B}$  of  $\mathbf{A}$  is term equivalent to the unique lattice on  $B$ , or every 2-element subalgebra  $\mathbf{B}$  of  $\mathbf{A}$  is term equivalent to the unique majority algebra on  $B$ , or every 2-element subalgebra  $\mathbf{B}$  of  $\mathbf{A}$  is a projection algebra (cf. Figure 1).  
(4.19) If  $\text{cro}_{\mathbf{A}} \geq 3$ , then  $\text{Iso}(\mathbf{A})$  is 2-complete.  
(4.20) If  $\text{Iso}(\mathbf{A})$  is 2-complete and  $\mathbf{A}$  has a compatible  $r \times 2$  cross, then all  $r \times 2$  crosses are compatible relations of  $\mathbf{A}$ .

For the proof of (4.14) it suffices to look at the relations  $\rho(a, x), \rho(x, a)$  ( $a \in A$ ) and  $\rho \cap \gamma\rho$  ( $\gamma \in \mathcal{S}_A$ ). To show (4.15) one can apply Theorem 3.1 and claim (4.12) to the subalgebra  $\mathbf{B}$  whose clone is  $\mathcal{S}_B$ -closed by (4.6). (4.16) follows by arguing that either  $\rho \cap (B \times C)$  is a  $2 \times 2$  cross for some 2-element subsets  $B, C$  of  $A$ , or one of the relations  $\rho \circ \rho^{-1}, \rho^{-1} \circ \rho$  is a nontrivial equivalence relation on a subset of  $A$  and hence (4.15) applies. Thus  $\mathbf{A}$  has a compatible  $2 \times 2$  cross in both cases. The proof of (4.17) requires slightly different arguments for the cases  $B = C, |B \cap C| = 1$ , and  $B \cap C = \emptyset$ . To prove (4.18) we consider a compatible  $2 \times 2$  cross  $\kappa = \kappa[b, B; c, C]$  of  $\mathbf{A}$ , which exists by (4.16) and (4.5). With the internal isomorphism  $\iota$  provided by (4.17) we get that  $\kappa \circ \iota^{-1}$  is a reflexive compatible cross of the 2-element subalgebra  $\mathbf{B}$  of  $\mathbf{A}$ . This fact, combined with (4.5), (4.6), and Example 2.1, implies (4.18). (4.19) can be derived from (4.17) by observing that if  $\kappa[b, B; c, C]$  is a compatible  $r \times 2$  cross of  $\mathbf{A}$ , then the  $2 \times 2$  crosses of the form  $\rho \cap (B' \times C)$  with  $b \in B' \subseteq B, |B'| = 2$ , yield enough bijections between 2-element subsets to conclude by properties (4.4)(2)–(3) that  $\mathbb{I} = \text{Iso}(\mathbf{A})$  is 2-complete. Finally, (4.20) is a special case of the following more general fact:

(4.21) If  $\text{Iso}(\mathbf{A})$  is 2-complete and  $\tau$  is a binary compatible relation of  $\mathbf{A}$  such that  $\text{pr}_2 \tau$  is a 2-element set, then

$$(\gamma \times \delta)_\tau = \{ \langle \gamma(x), \delta(y) \rangle : \langle x, y \rangle \in \tau \}$$

is a compatible relation of  $\mathbf{A}$  for all  $\gamma, \delta \in \mathcal{S}_A$ .

Indeed,  $(\gamma \times \delta)_\tau = \gamma_\tau \circ \iota$  for some bijection  $\iota$  between 2-element subsets of  $\mathbf{A}$ .

The next two claims are the core of the proof of Theorem 4.7; they are crucial in proving that the family  $\text{Iso}(\mathbf{A})$ , the parameter  $\text{cro}_\mathbf{A}$ , and the 2-element subalgebras of  $\mathbf{A}$  completely determine the reduced compatible relations of  $\mathbf{A}$ .

(4.22) If  $\rho$  is a reduced binary compatible relation of  $\mathbf{A}$  then the size of  $\rho$  is at most  $\text{cro}_\mathbf{A}$ ; moreover, if  $\rho$  is not a cross, then  $\text{cro}_\mathbf{A} \geq 3$  and the 2-element subalgebras of  $\mathbf{A}$  are projection algebras.

(4.23) If  $r = \text{cro}_\mathbf{A} \geq 3$  and the 2-element subalgebras of  $\mathbf{A}$  are projection algebras, then the  $r$ -element subalgebras of  $\mathbf{A}$  are also projection algebras and  $\text{Iso}(\mathbf{A})$  is  $r$ -complete.

For the proof of (4.22) let  $B = \text{pr}_1 \rho$ ,  $C = \text{pr}_2 \rho$ , and  $r = \text{cro}_\mathbf{A}$ . We can assume without loss of generality that  $|B| \geq |C|$ . For any compatible  $r \times 2$  cross  $\kappa[d, D; v, V]$  ( $d \in C$ ,  $V = \{v, v'\}$ ) of  $\mathbf{A}$ ,  $\rho \circ \kappa[d, D; v, V]$  is a compatible relation of  $\mathbf{A}$  of the form

$$\lambda = (E \times \{v\}) \cup (E' \times \{v'\}) \quad \text{with} \quad E \supseteq E' \neq \emptyset$$

where  $E = \bigcup \{ \rho(x, d') : d' \in C \cap D \}$  and  $E' = \rho(x, d)$ . Were  $|B| > r$ , we could select  $\kappa[d, D; v, V]$  (using conjugation) so that  $|E| > r$  and  $1 \leq |E'| < |E|$ . Therefore the same argument as in the proof of (4.19) would imply that  $\text{Iso}(\mathbf{A})$  is 2-complete. Hence, by (4.21), an intersection of some relations of the form  $(\gamma \times \text{id})\lambda$  with  $\gamma(E) = E$  ( $\gamma \in \mathcal{S}_A$ ) would be a compatible  $|E| \times 2$  cross of  $\mathbf{A}$ . This contradiction proves the statement on the size of  $\rho$ . If  $\rho$  is not a cross then, after replacing  $\rho$  with  $\rho^{-1}$  if necessary, we can select a compatible cross  $\kappa[d, D; v, V]$  (using conjugation) so that  $d \in C$ ,  $D \supseteq C$ , and for the compatible relation  $\lambda$  we have  $2 \leq |E'| < |E| (\leq |B|)$ . The size of  $\lambda$  is  $|E| \geq 3$ , therefore  $r = \text{cro}_\mathbf{A} \geq |E| \geq 3$  by the first part of (4.22). Thus (4.19)–(4.20) imply that every  $r \times 2$  cross is a compatible relation of  $\mathbf{A}$ . Hence for any  $r \times 2$  cross  $\kappa[e, E''; v', V]$  with  $e \in E \setminus E'$  and  $E' \cup \{e\} \subseteq E''$ ,  $\tau = \lambda \cap \kappa[e, E''; v', V]$  is a compatible relation of  $\mathbf{A}$  such that  $\tau \circ \tau^{-1}$  is a nontrivial equivalence relation on the set  $E' \cup \{e\}$ . Thus, by (4.15) and (4.5)–(4.6), all subalgebras of  $\mathbf{A}$  of size  $|E'| + 1$  are projection algebras.

To establish (4.23) let us fix a 2-element subalgebra  $\mathbf{C}$  of  $\mathbf{A}$ . It suffices to prove that for every term operation  $f = f(x_1, \dots, x_n)$  of  $\mathbf{A}$  such that  $f$  is projection onto the first variable in  $\mathbf{C}$ ,  $f$  is projection onto the first variable in every  $r$ -element subalgebra  $\mathbf{B}$  of  $\mathbf{A}$ ; thus the  $r$ -element subalgebras of  $\mathbf{A}$  are projection algebras, and any bijection between them or between smaller subalgebras is an internal isomorphism of  $\mathbf{A}$ . Let  $C = \{c, c'\}$  and let  $b_1, \dots, b_n$  be arbitrary elements of  $B$ . Since  $\kappa[b_1, B; c, C]$  is a

compatible relation of  $\mathbf{A}$  by (4.19)–(4.20), and since  $f(c', c, \dots, c) = c'$ , it follows that  $f(b_1, b_2, \dots, b_n) = b_1$ .

Now we can complete the proof of Theorem 4.7 through the following three claims:

- (4.24) If  $\text{cro}_{\mathbf{A}} > 2$  and the 2-element subalgebras of  $\mathbf{A}$  are not projection algebras, then (D) holds.
- (4.25) If  $\text{cro}_{\mathbf{A}} > 2$  and the 2-element subalgebras of  $\mathbf{A}$  are projection algebras, then (E) holds.
- (4.26) (D) or (E) holds also if  $\text{cro}_{\mathbf{A}} = 2$ .

Let  $r = \text{cro}_{\mathbf{A}}$ . In all three claims (4.24)–(4.26), the statements in (D) or (E), respectively, about  $\text{cro}_{\mathbf{A}}$  and  $\text{Iso}(\mathbf{A})$ , and the necessity of the conditions for  $f$  to be a term operation of  $\mathbf{A}$  follow from (4.16), (4.19), (4.23), and (4.18), (4.20), (4.23). It remains to check in each case that every operation  $f$  satisfying the conditions described in (D) or (E), respectively, is a term operation of  $\mathbf{A}$ . First assume that  $r \geq 3$  and that the 2-element subalgebras of  $\mathbf{A}$  are not projection algebras. Then  $\mathbf{A}$  has a term operation  $g$  that is a majority operation on some 2-element subalgebra of  $\mathbf{A}$ . By (4.19)  $\text{Iso}(\mathbf{A})$  is 2-complete, therefore  $g$  is a majority operation throughout  $\mathbf{A}$ . (4.22) shows that every reduced binary compatible relation of  $\mathbf{A}$  is a cross. Combining this with statements (4.19)–(4.20) and the fact that every  $r_1 \times r_2$  cross is a relational product of an  $r_1 \times 2$  and a  $2 \times r_2$  cross one can see that every operation  $f$  that satisfies the conditions described in (D) preserves all reduced binary compatible relation of  $\mathbf{A}$ . The following theorem of Baker and Pixley, modified in the spirit of claim (4.10), shows that  $f$  is a term operation of  $\mathbf{A}$ :

**Theorem 4.27.** [1] *If a finite algebra  $\mathbf{A}$  has a majority term operation, then an operation on  $A$  is a term operation of  $\mathbf{A}$  if and only if it preserves the internal isomorphisms of  $\mathbf{A}$  and the binary reduced compatible relations of  $\mathbf{A}$ .*

If  $r \geq 3$  and the 2-element subalgebras of  $\mathbf{A}$  are projection algebras, then Theorem 4.11 and (4.22) yield that every reduced compatible relation of  $\mathbf{A}$  has size  $\leq r$ . All such relations are preserved by every operation  $f$  that satisfies the conditions described in (E). Thus it follows immediately from (4.10) that  $f$  is a term operation of  $\mathbf{A}$ . Finally, if  $r = 2$ , then we know from Theorem 4.11 and (4.22) that every reduced compatible relation  $\sigma$  of  $\mathbf{A}$  has size  $\leq 2$ . It is not hard to prove by induction on the arity  $n$  of  $\sigma$ , and using (4.17), that for any indices  $1 \leq i < j \leq n$  there exist internal isomorphisms  $\iota_{ij}: \text{pr}_i \sigma \rightarrow \text{pr}_j \sigma$ . Therefore  $\sigma$  arises from a compatible relation  $\sigma'$  of the 2-element subalgebra  $\mathbf{B}$  of  $\mathbf{A}$  on  $B = \text{pr}_1 \sigma$  by applying the internal isomorphisms  $\iota_{12}, \dots, \iota_{1n}$  in the 2nd,  $\dots$ ,  $n$ -th coordinates. Thus every operation  $f$  that satisfies the conditions described in (D) or (E), respectively, for  $r = 2$  preserves  $\sigma$ . This holds for every reduced compatible relation  $\sigma$ , so we get from (4.10) that  $f$  is a term operation of  $\mathbf{A}$ .  $\square$

In conclusion we note that the description of  $\mathcal{S}_A$ -closed clones was extended by Marchenkov to  $\mathcal{A}_A$ -closed clones. For  $|A| = 3$  there are  $2^{\aleph_0}$   $\mathcal{A}_A$ -closed clones (see [24]), but for  $|A| \geq 4$  there are only finitely many (see [29, 30, 31, 32]), and their description is very similar to the description of the  $\mathcal{S}_A$ -closed clones. In fact, it turns out that if  $|A|$  is not divisible by 4, then every  $\mathcal{A}_A$ -closed clone is in fact  $\mathcal{S}_A$ -closed. If  $|A|$  is divisible by 4, then there exist  $\mathcal{A}_A$ -closed clones  $\mathfrak{C}$  satisfying condition (I) that are not  $\mathcal{S}_A$ -closed, because there exist  $\mathcal{A}_A$ -closed families of internal isomorphisms that are not  $\mathcal{S}_A$ -closed. Such families of internal isomorphisms exist for the following reason: if  $|A|$  is divisible by 4, then  $\text{Bij}_{|A|/2}^\circ(A)$  can be partitioned into two subsets of equal size so that both families are  $\mathcal{A}_A$ -closed and satisfy (4.4)(2), but they are not  $\mathcal{S}_A$ -closed.

## 5. FINITENESS OF THE LATTICE OF $G$ -CLOSED CLONES

The results discussed in the preceding section show that the lattice of  $G$ -closed clones on a finite universe  $A$  is finite if  $G = \mathcal{S}_A$  or if  $|A| \geq 4$  and  $G = \mathcal{A}_A$ . One wonders: Are there any other permutation groups  $G$  for which the lattice of  $G$ -closed clones is finite? At the present time the answer to this question is not known. However, the main theorem of this section shows that there are very few possible candidates for such a  $G$ . This theorem determines all groups  $G$  for which the number of  $G$ -closed clones that contain all constants is finite.

**Theorem 5.1.** [20] *For a permutation group  $G \subseteq \mathcal{S}_A$  where  $A$  is finite,  $|A| \geq 3$ , the following conditions are equivalent:*

- (i) *The lattice of  $G$ -closed clones that contain all constants is finite.*
- (ii)  *$G$  satisfies the following combinatorial condition:*
  - (\*) *for every integer  $k$  ( $2 \leq k < |A|$ ), for every  $(k+1)$ -element subset  $B$  of  $A$ , and for every  $k$ -element subset  $C$  of  $B$ , there exists a  $k$ -element subset  $C'$  of  $B$  such that  $C' \neq C$  and  $C' = \gamma(C)$  for some  $\gamma \in G$ .*
- (iii)  *$G$  is one of the following groups:  $\mathcal{S}_A$ ,  $\mathcal{A}_A$ ,  $\text{AGL}(1, 5)$  ( $|A| = 5$ ),  $\text{PSL}(2, 5)$  ( $|A| = 6$ ),  $\text{PGL}(2, 5)$  ( $|A| = 6$ ),  $\text{PGL}(2, 7)$  ( $|A| = 8$ ),  $\text{PGL}(2, 8)$  ( $|A| = 9$ ),  $\text{PTL}(2, 8)$  ( $|A| = 9$ ).*

*Outline of proof.* To prove the implication (i) $\Rightarrow$ (ii) we assume that (ii) fails, and construct infinitely many  $G$ -closed clones that contain all constants. To witness the failure of (ii) we fix an integer  $k$  ( $2 \leq k < |A|$ ), a  $k$ -element subset  $C$  of  $A$ , and a  $(k+1)$ -element subset  $B = C \cup \{0\}$  of  $A$  so that  $\gamma(C) \neq C'$  for every  $\gamma \in G$  and for every  $k$ -element subset  $C'$  of  $B$  that contains 0. For notational simplicity let us assume that  $C = \{1, 2, \dots, k\}$ . Using these sets we construct an infinite sequence  $\rho_n$  ( $n = 2, 3, \dots$ ) of relations and an infinite sequence  $f_n$  ( $n = 3, 4, \dots$ ) of operations on  $A$  as follows:  $\rho_n$  is the  $(n+k-1)$ -ary relation consisting of all tuples  $\langle x_1, \dots, x_n, y_1, \dots, y_{k-1} \rangle \in A^{n+k-1}$  such that  $|\{x_1, \dots, x_n, y_1, \dots, y_{k-1}\}| \leq k+1$  and



if  $\{x_1, \dots, x_n, y_1, \dots, y_{k-1}\} = \gamma(C)$  for some  $\gamma \in G$  then  $|\{x_1, \dots, x_n\}| \geq 2$ ;  $f_n$  is the  $n$ -ary operation on  $A$  such that  $f_n(1, \dots, 1, 0, 1, \dots, 1) = 1$  (with 0 occurring in the  $j$ -th position) for every  $j$  ( $1 \leq j \leq n$ ),  $f_n(c, \dots, c) = c$  for all  $c = 2, \dots, k$ , and  $f_n(x_1, \dots, x_n) = 0$  for all remaining arguments. It is not hard to check that

- every  $\rho_n$  is reflexive and satisfies  $\gamma\rho_n = \rho_n$  for all  $\gamma \in G$ ; therefore the clone  $\mathfrak{C}(\rho_n)$  consisting of all operations that preserve the relation  $\rho_n$  is  $G$ -closed and contains all constants;
- $\mathfrak{C}(\rho_{n-1}) \supseteq \mathfrak{C}(\rho_n)$  for all  $n \geq 3$ ;
- the inclusions are proper, as  $f_n \in \mathfrak{C}(\rho_{n-1}) \setminus \mathfrak{C}(\rho_n)$  for all  $n \geq 3$ .

The proof of the implication (ii) $\Rightarrow$ (iii) is purely group theoretical. It is clear that condition (ii) holds for  $G$  if  $G$  is  $k$ -homogeneous for every  $k$  ( $1 \leq k < |A|$ ). Therefore the implication (ii) $\Rightarrow$ (iii) generalizes the following classical theorem:

**Theorem 5.2.** [2] *The permutation groups on a finite set  $A$  ( $|A| \geq 3$ ) that are  $k$ -homogeneous for every  $k$  ( $1 \leq k < |A|$ ) are the following:  $\mathcal{S}_A$ ,  $\mathcal{A}_A$ ,  $\text{AGL}(1, 5)$  ( $|A| = 5$ ),  $\text{PGL}(2, 5)$  ( $|A| = 6$ ),  $\text{PGL}(2, 8)$  ( $|A| = 9$ ), and  $\text{P}\Gamma\text{L}(2, 8)$  ( $|A| = 9$ ).*

If  $G$  satisfies the weaker assumption (\*), then condition (\*) for  $k = 2$  immediately implies that  $G$  must be 2-homogeneous. It is not hard to argue that condition (\*) fails for the group  $\text{AGL}(d, p)$  unless  $p^d \leq 5$ . This implies that every affine 2-homogeneous group  $G$  that satisfies (\*) is listed in (iii). For almost simple 2-transitive groups  $G$  we use the classification theorem to prove that (\*) fails unless  $G$  is listed in (iii).

Finally, to establish the implication (iii) $\Rightarrow$ (i) we extend the method of proof of Theorem 4.1 presented in the previous section from the case  $G = \mathcal{S}_A$  to all groups  $G$  listed in (iii).  $\square$

## REFERENCES

- [1] K. A. Baker, A. F. Pixley, *Polynomial interpolation and the chinese remainder theorem for algebraic systems*, Math. Z. **143** (1975), 165–174.
- [2] R. A. Beaumont, R. P. Peterson, *Set transitive permutation groups*, Canad. J. Math. **7** (1955), 35–42.
- [3] G. A. Burle, *Classes of  $k$ -valued logic which contain all functions of a single variable* (Russian), Diskret. Analiz (Novosibirsk) **10** (1967), 3–7.
- [4] P. J. Cameron, *Permutation Groups*, London Mathematical Society Student Texts 45, Cambridge University Press, Cambridge, 1999.
- [5] D. M. Clark, P. H. Krauss, *Para primal algebras*, Algebra Universalis **6** (1976), no. 2, 165–192.
- [6] B. Csákány, T. Gavalcová, *Finite homogeneous algebras. I*, Acta Sci. Math. (Szeged) **42** (1980), 57–65.
- [7] K. Denecke, S. L. Wismath, *Galois connenctions and complete sublattices*, Galois Connections and Applications (Editors: K. Denecke, M. Erné, S. L. Wismath), Kluwer, 2003.
- [8] K. Głazek, St. Niwczyk,  *$Q$ -Independence and weak automorphisms*, Galois Connections and Applications (Editors: K. Denecke, M. Erné, S. L. Wismath), Kluwer, 2003.
- [9] A. Goetz, *On weak isomorphisms and weak homomorphisms of abstract algebras*, Colloq. Math. **14** (1966), 163–167.

- [10] M. Goldstern, S. Shelah, *Clones on regular cardinals*, Fund. Math. **173** (2002), no. 1, 1–20.
- [11] V. V. Gorlov, R. Pöschel, *Clones closed with respect to permutation groups or transformation semigroups*, Beiträge Algebra Geom. **39** (1998), 181–204.
- [12] L. Haddad, I. G. Rosenberg, *Finite clones containing all permutations*, Canad. J. Math. **46** (1994), 951–970.
- [13] Nguen Van Khoa [Nguen Van Hoa], *On the structure of self-dual closed classes of three-valued logic  $P_3$*  (Russian), Diskret. Mat. **4** (1992), no. 4, 82–95.
- [14] Nguen Van Khoa, *Families of closed classes of  $k$ -valued logic that are preserved by all automorphisms* (Russian), Diskret. Mat. **5** (1993), no. 4, 87–108.
- [15] Nguen Van Khoa, *Description of closed classes that are preserved by all inner automorphisms of  $k$ -valued logic* (Russian), Dokl. Akad. Nauk Belarusi **38** (1994), no. 3, 16–19, 122.
- [16] Nguen Van Khoa *On closed classes of  $k$ -valued logic that are self-dual with respect to transitive groups* (Russian), Diskret. Mat. **8** (1996), no. 1, 129–159; translation in: Discrete Math. Appl. **6** (1996), no. 2, 179–206; announcement of results in: *On the structure of closed classes of  $k$ -valued logic that are self-dual with respect to transitive groups* (Russian), Dokl. Akad. Nauk Belarusi **38** (1994), no. 6, 17–20, 121 (1995).
- [17] D. Hobby, R. McKenzie, *The Structure of Finite Algebras*, Contemporary Mathematics **76**, American Mathematical Society, Providence, RI, 1988.
- [18] B. Huppert, N. Blackburn, *Finite Groups III*, Grundlehren der Mathematischen Wissenschaften, vol. 243, Springer-Verlag, Berlin–New York, 1982.
- [19] K. A. Kearnes, E. W. Kiss, M. Valeriote, *Minimal sets and varieties*, Trans. Amer. Math. Soc. **350** (1998), no. 1, 1–41.
- [20] K. A. Kearnes, Á. Szendrei, *Clones closed under conjugation*, in preparation.
- [21] I. Levi, R. B. McFadden,  *$S_n$ -normal semigroups*, Proc. Edinburgh Math. Soc. (2) **37** (1994), no. 3, 471–476.
- [22] A. I. Mal'tsev, *A strengthening of the theorems of Stupecki and Yablonskiĭ* (Russian), Algebra i Logika **6** (1967), 61–75.
- [23] S. S. Marchenkov, *Homogeneous algebras* (Russian), Problemy Kibernet. **39** (1982), 85–106; announcement of results in: *On homogeneous algebras* (Russian), Dokl. Akad. Nauk SSSR **256** (1981), no. 4, 787–790.
- [24] S. S. Marchenkov, *Closed classes of self-dual functions of many-valued logic. II* (Russian), Problemy Kibernet. **40** (1983), 261–266.
- [25] S. S. Marchenkov, *Classification of algebras with an alternating group of automorphisms* (Russian), Mathematical problems in cybernetics, No. 2, 100–122, "Nauka", Moscow, 1989; announcement of results in: *On the classification of algebras whose automorphism group is the alternating group* (Russian), Dokl. Akad. Nauk SSSR **265** (1982), no. 3, 533–536.
- [26] S. S. Marchenkov,  *$G$ -precomplete classes of many-valued logic* (Russian), Diskret. Anal. Issled. Oper. **3** (1996), no. 3, 47–70, 111.
- [27] S. S. Marchenkov, *Basic relations for the  $S$ -classification of functions of multivalued logic* (Russian), Diskret. Mat. **8** (1996), no. 1, 99–128; translation in: Discrete Math. Appl. **6** (1996), no. 2, 149–178.
- [28] S. S. Marchenkov,  *$S$ -classification of functions of many-valued logic* (Russian), Diskret. Mat. **9** (1997), no. 3, 125–152; translation in: Discrete Math. Appl. **7** (1997), no. 4, 353–381; announcement of results in:  *$S$ -classification of idempotent algebras with finite support* (Russian), Dokl. Akad. Nauk **348** (1996), no. 5, 587–589.
- [29] S. S. Marchenkov,  *$A$ -classification of finite injective functions* (Russian), Diskretn. Anal. Issled. Oper. Ser. 1 **4** (1997), no. 2, 15–42, 115.

- [30] S. S. Marchenkov, *A-closed classes of idempotent functions of many-valued logic that are defined by two-place relations* (Russian), *Diskretn. Anal. Issled. Oper. Ser. 1* **5** (1998), no. 1, 32–59, 104.
- [31] S. S. Marchenkov, *A-closed classes of many-valued logic that contain constants* (Russian), *Diskret. Mat.* **10** (1998), no. 3, 10–26; translation in: *Discrete Math. Appl.* **8** (1998), no. 4, 357–374.
- [32] S. S. Marchenkov, *A-classification of idempotent functions of many-valued logic* (Russian), *Diskretn. Anal. Issled. Oper. Ser. 1* **6** (1999), no. 1, 19–43, 97; announcement of results of [31], [32] in: *Dokl. Akad. Nauk* **366** (1999), no. 4, 455–457.
- [33] P. P. Pálffy, *Unary polynomials in algebras I*, *Algebra Universalis* **18** (1984), 262–273.
- [34] R. Pöschel, *Galois connections for operations and relations*, *Galois Connections and Applications* (Editors: K. Denecke, M. Ern e, S. L. Wismath), Kluwer, 2003.
- [35] R. Pöschel, L. A. Kalu znin, *Funktionen- und Relationenalgebren*, VEB Deutscher Verlag der Wissenschaften, Berlin, 1979; Birkh user Verlag, Basel and Stuttgart, 1979.
- [36] E. L. Post, *The Two-Valued Iterative Systems of Mathematical Logic*, *Ann. Math. Studies* **5**, Princeton University Press, Princeton, N.J., 1941.
- [37] J. S lupceki, *Completeness criterion for systems of many-valued propositional logics*, *C. R. S ances Soc. Sci. Lettres Varsovie Cl. III* **32** (1939), 102–109. English translation: *Studia Logica* **30** (1972), 153–157.
- [38] L. Szab , *Algebras that are simple with weak automorphisms*, *Algebra Universalis* **42** (1999), 205–233.
- [39]  . Szendrei, *Clones in Universal Algebra*, *S minaire de Math matiques Sup rieures*, vol. 99, Les Presses de l’Universit  de Montr al, Montr al, 1986.
- [40]  . Szendrei, *Simple surjective algebras having no proper subalgebras*, *J. Austral. Math. Soc. Ser. A* **48** (1990), 434–454.
- [41]  . Szendrei, *Strongly Abelian minimal varieties*, *Acta Sci. Math.* **59** (1994), 25–42.
- [42] S. V. Yablonski , *Functional constructions in a  $k$ -valued logic* (Russian), *Trudy Mat. Inst. Steklov.* **51** (1958), 5–142.

( gnes Szendrei) BOLYAI INSTITUTE, UNIVERSITY OF SZEGED, ARADI V RTAN K TERE 1,  
H-6720 SZEGED, HUNGARY.

*E-mail address:* A.Szendrei@math.u-szeged.hu